

# JUNIOR TWIN LOFT BED

Model Number:	UPC Code:	Color:
DA8377	0-65857-19262-9	White
DA8377-E	0-65857-19287-2	Espresso
DA8377-BL	0-65857-19907-9	Blue
DA8377-BK	0-65857-19908-6	Black
DA8377-GR	0-65857-19909-3	Gray

Congratulations on your latest furniture purchase! **Dorel Living** furniture has been developed with quality, convenience and style in mind. We trust it will provide you with many years of exceptional comfort and service.

Before beginning assembly, we encourage you to familiarize yourself with your new furniture piece by taking a few minutes to go through this booklet. It contains important information on our warranty and care tips to keep your furniture looking as good as new.

For more great furniture ideas, check out our website at [www.dorelliving.com](http://www.dorelliving.com)  
You can also keep up to date on all the latest trends by liking our [Facebook page](#) and [Instagram page](#).

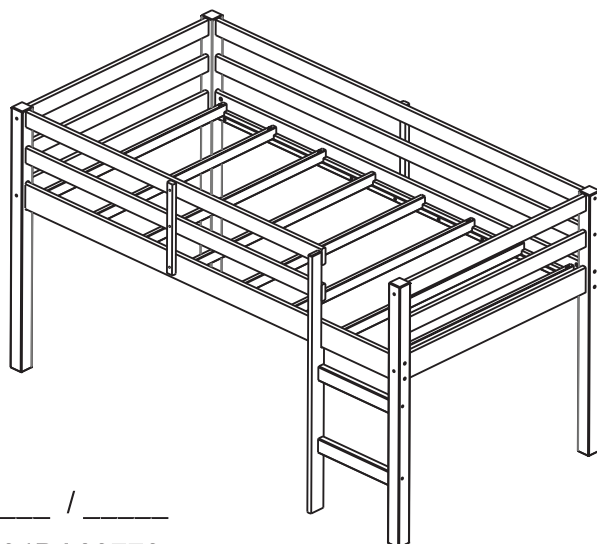

Distributed by / Distribué par:	
<b>Dorel Asia Inc.</b>	
410 East First Street, South, Wright City, MO, USA 63390	
Model / Modèle:	DA8377/DA8377-BK DA8377-BL/DA8377-E DA8377-GR
Factory / Usine:	136832
Date of / de Production:	2020/06
IM #:	B34DA837701
Color:	White/Black Blue/ Espresso Gray
Made in Brazil / Fabriqué au Brésil	

Date of Purchase: \_\_\_\_ / \_\_\_\_ / \_\_\_\_

Instruction Manual number : B34DA837702-136832

Lot Number: \_\_\_\_\_  
(taken from carton)

Questions, concerns, missing parts? Customer satisfaction is important to us at Dorel Asia. **CONTACT OUR CUSTOMER SERVICE DEPARTMENT BEFORE RETURNING PRODUCT TO THE RETAILER.**

**cs@dhpffurniture.com**

1-800-267-1739

Monday to Friday 9:00 am to 9:00 pm (Eastern Time)

Saturday 10 am to 6:30 pm (Eastern Time)

Sunday 11 am to 7 pm (Eastern Time)

**DHP Consumer Services**

12345 Albert Hudon, Suite 100,

Montreal, Quebec, Canada H1G 3L1

**NOTE: THIS INSTRUCTION BOOKLET CONTAINS IMPORTANT SAFETY INFORMATION. PLEASE READ AND KEEP FOR FUTURE REFERENCE.**

## CUSTOMER SERVICE

You can also contact us by writing to the address listed below. Please include the product model number, color and a detailed description of your enquiry.

**DHP Consumer Services**  
**12345 Albert-Hudon Boulevard, Suite 100**  
**Montreal, Quebec**  
**Canada, H1G 3L1**

## NOTES AND INSTALLATION

- \* READ EACH STEP CAREFULLY BEFORE STARTING. IT IS VERY IMPORTANT THAT EACH STEP OF INSTRUCTION IS PERFORMED IN THE CORRECT ORDER. IF THESE STEPS ARE NOT FOLLOWED IN SEQUENCE, ASSEMBLY DIFFICULTIES WILL OCCUR AND CAN RESULT IN INJURY.
- \* **CAUTION:** ADULT ASSEMBLY REQUIRED.
- \* MAKE SURE ALL PARTS ARE INCLUDED. WORK IN SPACIOUS AREA, PREFERABLY ON A SMOOTH SOFT SURFACE.
- \* ASSEMBLY WILL REQUIRE TWO PEOPLE.
- \* MOST BOARD PARTS ARE LABELED OR STAMPED ON THE RAW EDGE.
- \* PHILLIPS SCREWDRIVER (NOT INCLUDED) IS REQUIRED.
- \* A RUBBER Mallet (NOT INCLUDED) IS RECOMMENDED TO FACILITATE ASSEMBLY.
- \* BED IS DESIGNED FOR CHILDREN RANGING FROM 4 YEARS OF AGE TO YOUNG TEENAGERS.

## CARE, CLEANING AND MAINTENANCE

Dust regularly with a soft, dry cloth. We do not recommend the use of chemical cleaners or wax on our lacquered furniture as it may damage the finish. Keep solvents, alcohol, nail polish and polish removers away from your hardwood furniture surfaces.

Check all bolts, screws and fasteners periodically and tighten them if necessary.

## 1-YEAR LIMITED WARRANTY

Dorel warrants its product to be free from defects in material and workmanship and agrees to remedy any such defect. This warranty covers 1 year from the date of original purchase from authorized retailers. This warranty is valid only upon presentation of proof of purchase. This is solely limited to the repair or replacement of defective furniture components and no assembly labor is included. This warranty does not apply to any product which has been improperly assembled, subjected to misuse or abuse or which has been altered or repaired in any way. The warranty does not cover wearing, tearing, fading or splitting of the fabric (where applicable). This warranty gives you specific legal rights and you may also have other rights which vary from State to State or Province to Province.



**WARNING: Should this product become damaged, and/or components are broken or missing, DO NOT USE.**







# WARNING

- \* **STRANGULATION HAZARD** - NEVER ATTACH OR HANG ITEMS TO ANY PART OF THE BUNK BED THAT ARE NOT DESIGNED FOR USE WITH THE BED; FOR EXAMPLE, BUT NOT LIMITED TO, HOOKS, BELTS AND JUMP ROPES.
- \* FOLLOW THE INFORMATION ON THE WARNINGS APPEARING ON THE UPPER BUNK END STRUCTURE AND ON THE CARTON. DO NOT REMOVE WARNING LABEL FROM BED.
- \* THE MATTRESS PLATFORM IS DESIGNED TO SUPPORT A MATTRESS WITHOUT THE NEED FOR A POSTURE BOARD OR BOX SPRING.
- \* ALWAYS USE THE RECOMMENDED SIZE MATTRESS OR MATTRESS SUPPORT, OR BOTH, TO HELP PREVENT THE LIKELIHOOD OF ENTRAPMENT OR FALLS.
- \* **USE ONLY COIL SPRING MATTRESSES ON BED. FAILURE TO DO SO CAN RESULT IN INJURY.**
- \* USE ONLY MATTRESSES WHICH IS 74"-75" LONG AND 37 1/2" - 38 1/2" WIDE ON BED. ENSURE THICKNESS OF MATTRESS DOES NOT EXCEED 6". SURFACE OF MATTRESS MUST BE AT LEAST 5" (127MM) BELOW THE UPPER EDGE OF GUARDRAILS.
- \* DO NOT ALLOW CHILDREN UNDER 4 YEARS OF AGE TO USE THE UPPER BUNK.
- \* ALWAYS USE GUARDRAILS ON BOTH LONG SIDES OF THE UPPER BUNK. IF THE BUNK BED WILL BE PLACED NEXT TO THE WALL, THE GUARDRAIL THAT RUNS THE FULL LENGTH OF THE BED SHOULD BE PLACED AGAINST THE WALL TO PREVENT ENTRAPMENT BETWEEN THE BED AND WALL (APPLICABLE FOR BUNK BEDS WITH FULL LENGTH GUARDRAILS ON ONE SIDE).
- \* PERIODICALLY CHECK AND ENSURE THAT THE GUARDRAIL, LADDER AND OTHER COMPONENTS ARE IN THEIR PROPER POSITION, FREE FROM DAMAGE, AND THAT ALL CONNECTORS ARE TIGHT.
- \* DO NOT ALLOW HORSEPLAY ON OR UNDER THE BED AND PROHIBIT JUMPING ON THE BED.
- \* DO NOT USE SUBSTITUTE PARTS. CONTACT CUSTOMER SERVICE FOR REPLACEMENT PARTS.
- \* USE OF A NIGHT LIGHT MAY PROVIDE ADDED SAFETY PRECAUTION FOR A CHILD USING THE UPPER BUNK.
- \* THE USE OF WATER OR SLEEP FLOTATION MATTRESSES IS PROHIBITED.
- \* ALWAYS USE THE LADDER FOR ENTERING AND LEAVING THE UPPER BUNK.
- \* PROHIBIT MORE THAN ONE PERSON ON UPPER BUNK.
- \* KEEP THESE INSTRUCTIONS FOR FUTURE USE.

# JUNIOR TWIN LOFT BED

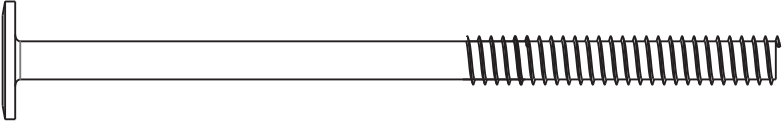
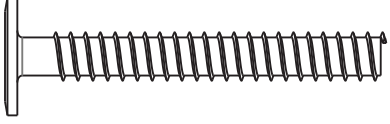
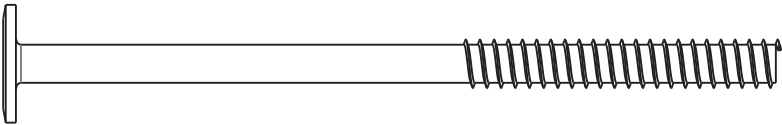
DA8377 / DA8377-E / DA8377-BL / DA8377-BK / DA8377-GR

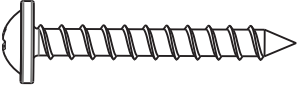
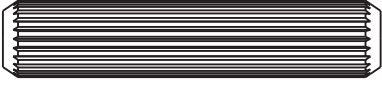
## HARDWARELIST

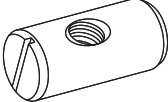
<p><b>1</b></p>  <p>1/4" x 100mm</p>	<p><b>2</b></p>  <p>6.5mm x 48mm</p>
<p>JOINT CONNECTOR (4mm HEX HEAD) 8 PCS</p>	<p>WOOD JOINT CONNECTOR (4mm HEX HEAD) 6 PCS</p>
<p><b>3</b></p>  <p>6.5mm x 100mm</p>	<p><b>4</b></p>  <p>4mm x 35mm</p>
<p>WOOD JOINT CONNECTOR (4mm HEX HEAD) 16 PCS</p>	<p>FLAT HEAD WOOD SCREW 12 PCS</p>
<p><b>5</b></p>  <p>4mm x 35mm</p>	<p><b>6</b></p>  <p>10mm x 50mm</p>
<p>FLANGE SCREW 6 PCS</p>	<p>WOOD DOWEL 34 PCS</p>
<p><b>7</b></p>  <p>ALLEN KEY 1 PC</p>	<p><b>8</b></p>  <p>11.8mm x 15mm BARREL NUT 8 PCS</p>

# JUNIOR TWIN LOFT BED

DA8377 / DA8377-E / DA8377-BL / DA8377-BK / DA8377-GR

## Hardware Pack

DA8377-E (Espresso) DA8377-BL (Blue) DA8377-BK (Black) DA8377-GR (Gray)	HP#: <input checked="" type="checkbox"/> TDA8377-BK-00
DA8377 (White)	HP#: <input type="checkbox"/> TDA8377-00

 Please do not completely tighten all the hardware, until the entire assembly is complete, unless otherwise indicated in the step-by-step instructions.

 The screw(s), bolt(s) to be used at each step are shown in actual size in the lower right corner of the page.

# JUNIOR TWIN LOFT BED

DA8377 / DA8377-E / DA8377-BL / DA8377-BK / DA8377-GR

## PARTS LIST

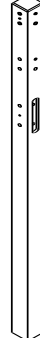
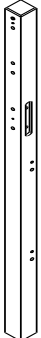
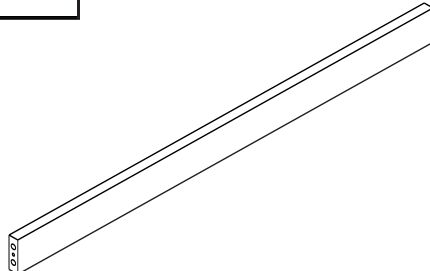
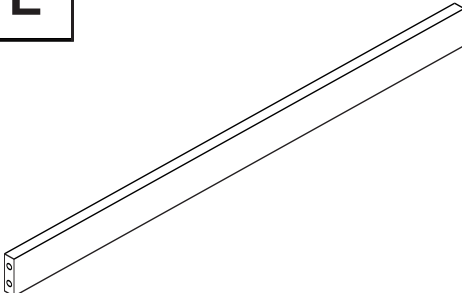
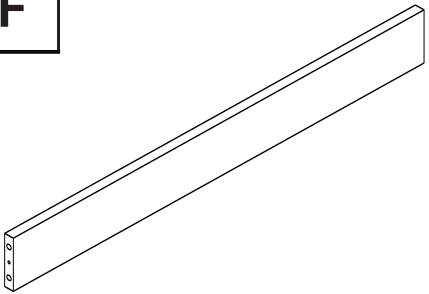

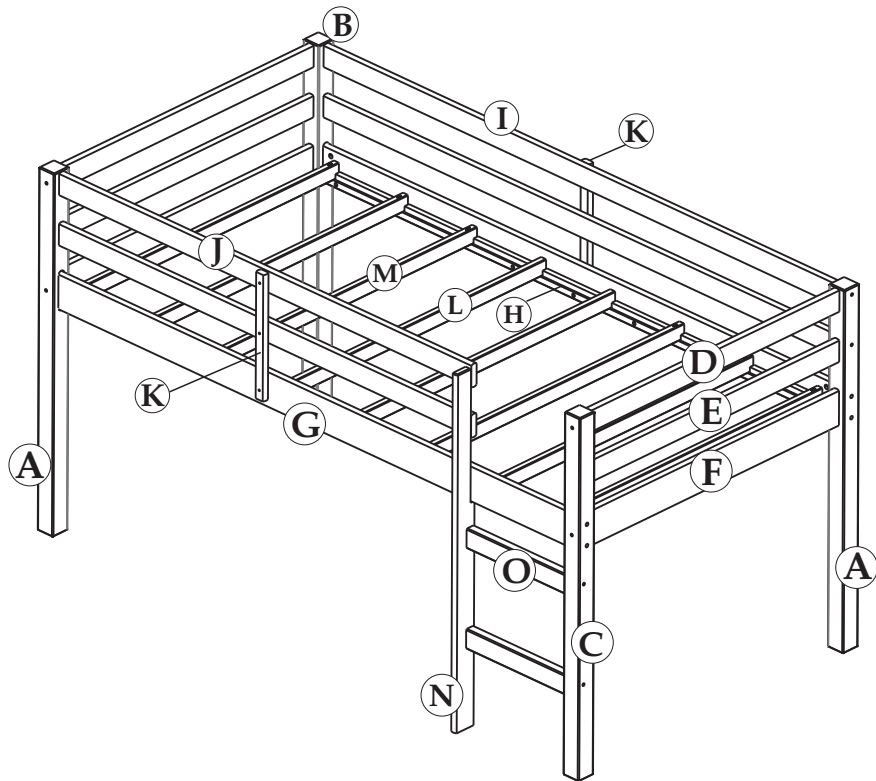

<p><b>A</b></p> 	<p><b>B</b></p> 	<p><b>C</b></p> 
<p>POST 2 PCS</p>	<p>POST 1 PC</p>	<p>POST 1 PC</p>
<p><b>D</b></p> 	<p><b>E</b></p> 	<p><b>F</b></p> 
<p>HEADBOARD TOP CROSS 2 PCS</p>	<p>HEADBOARD CENTER CROSS 2 PCS</p>	<p>HEADBOARD BOTTOM CROSS 2 PCS</p>

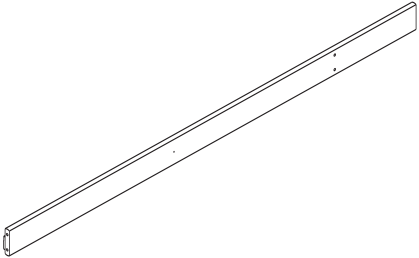
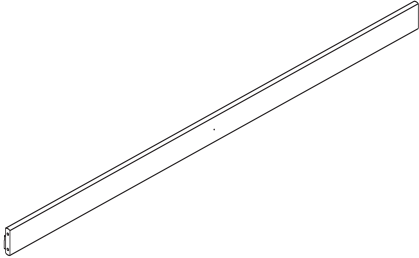
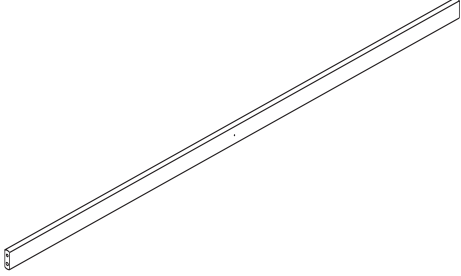
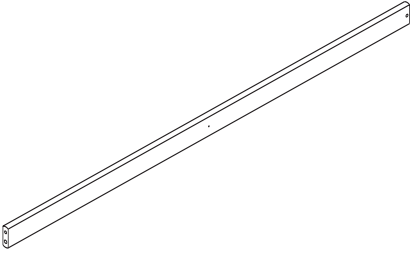

# JUNIOR TWIN LOFT BED

DA8377 / DA8377-E / DA8377-BL / DA8377-BK / DA8377-GR

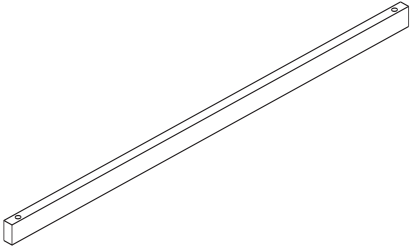
## PARTS LIST

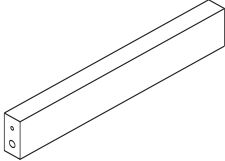
<p><b>G</b></p> 	<p><b>H</b></p> 	<p><b>I</b></p> 
<p>SIDE RAIL (WITH 3 HOLE) 1 PC</p>	<p>SIDE RAIL (WITH 1 HOLE) 1 PC</p>	<p>LONG GUARDRAIL 2 PCS</p>
<p><b>J</b></p> 	<p><b>K</b></p> 	<p><b>L</b></p> 
<p>SHORT GUARDRAIL 2 PCS</p>	<p>GUARDRAIL LEG 2 PCS</p>	<p>SLAT 2 PCS</p>
<p><b>M</b></p> 	<p><b>N</b></p> 	<p><b>O</b></p> 
<p>SLAT 6 PCS</p>	<p>LADDER END 1 PC</p>	<p>LADDER STEP 2 PCS</p>

# JUNIOR TWIN LOFT BED

DA8377 / DA8377-E / DA8377-BL / DA8377-BK / DA8377-GR

## PARTS

For replacement parts, visit [www.dhpfurniture.com/spa/replacement-parts](http://www.dhpfurniture.com/spa/replacement-parts)

**IMPORTANT:** Each part has a unique part number. Please reference the appropriate part number when contacting customer service for replacement parts.

PART NUMBERS					
PART LABELS	DA8377 (White)	DA8377-E (Espresso)	DA8377-BL (Blue)	DA8377-BK (Black)	DA8377-GR (Grey)
A	T995720	T995870	T996020	T996170	T996320
B	T995730	T995880	T996030	T996180	T996330
C	T995740	T995890	T996040	T996190	T996340
D	T995750	T995900	T996050	T996200	T996350
E	T995760	T995910	T996060	T996210	T996360
F	T995770	T995920	T996070	T996220	T996370
G	T995780	T995930	T996080	T996230	T996380
H	T995790	T995940	T996090	T996240	T996390
I	T995800	T995950	T996100	T996250	T996400
J	T995810	T995960	T996110	T996260	T996410
K	T995820	T995970	T996120	T996270	T996420
L	T995830	T995980	T996130	T996280	T996430
M	T995840	T995990	T996140	T996290	T996440
N	T995850	T996000	T996150	T996300	T996450
O	T995860	T996010	T996160	T996310	T996460



# JUNIOR TWIN LOFT BED

DA8377 / DA8377-E / DA8377-BL / DA8377-BK / DA8377-GR

## STEP 1

One of the headboard top crosses (D) has a label on it, use it in this step.

Insert wood dowels (6) into the ends of headboard top cross (D), headboard bottom cross (F) and headboard center cross (E).

Attach headboard crosses (D, F, E) to posts (A) & (B) using wood joint connectors (3) as shown below. Use the Allen key (7) to tighten the wood joint connectors.

Repeat the previous step to assemble the other headboard using the bottom posts (C) and (A).

**NOTE:** Pull the headboard crosses (D, F, E) closer together or further apart in order to allow the wood dowels (6) to align with the holes on posts (A) and (B).

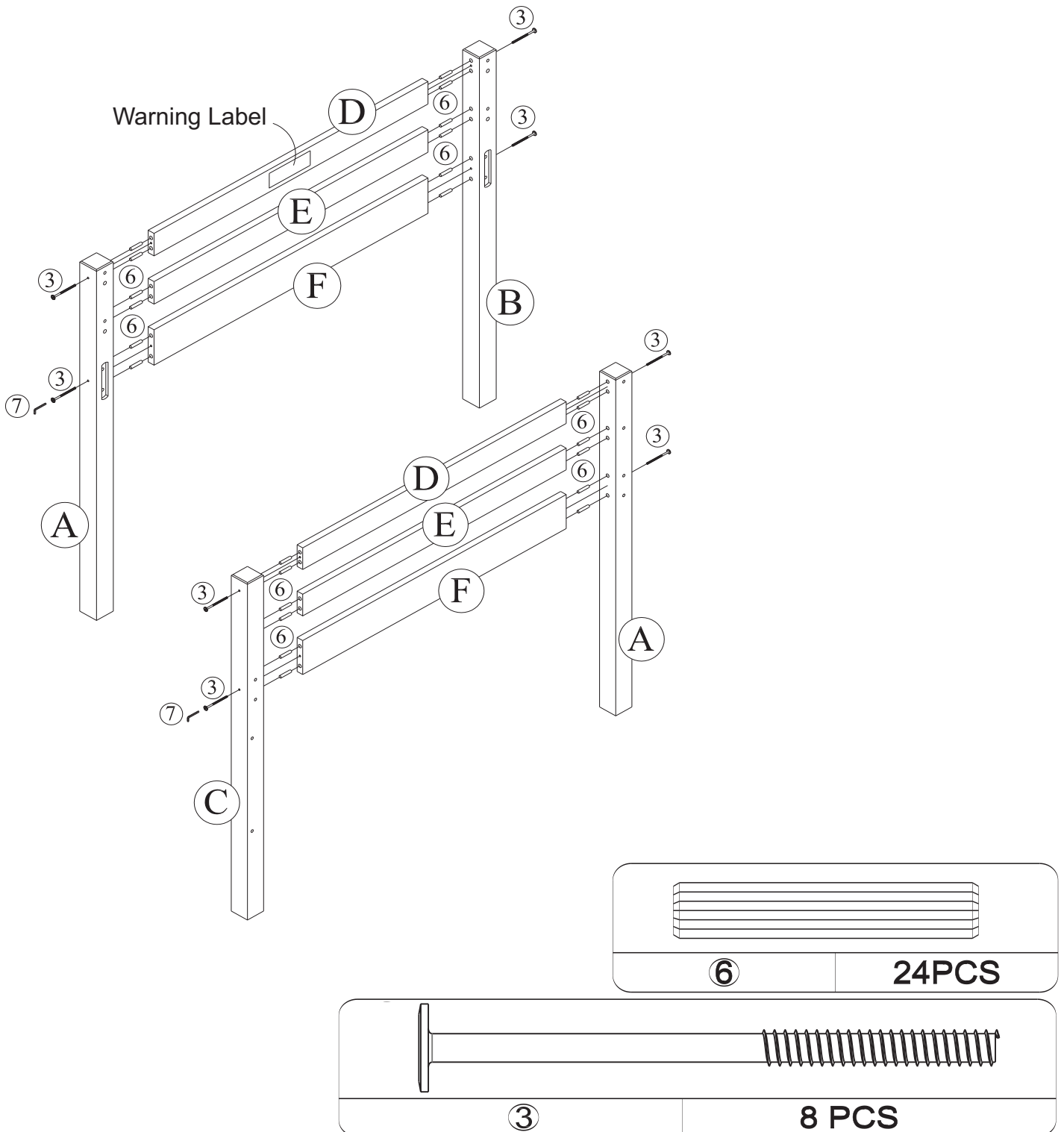

# JUNIOR TWIN LOFT BED

DA8377 / DA8377-E / DA8377-BL / DA8377-BK / DA8377-GR

## STEP 2

Insert wood dowels (6) into each end of the long guardrails (I). Attach long guardrails (I) and side rails (G) and (H) to posts (A & B) and (A & C) as shown below.

Fasten the side rails (G) and (H) with joint connectors (1) and barrel nuts (8). Fasten long guardrails (I) with wood joint connectors (3).

Use Allen key (7) to tighten all joint connectors.

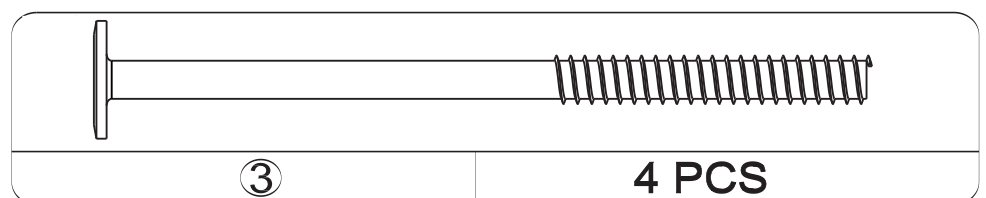
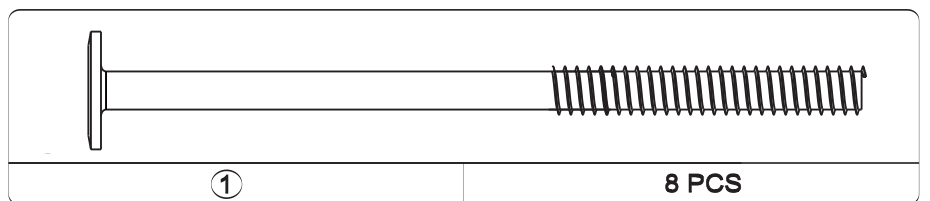
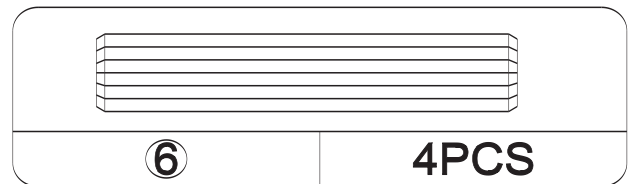
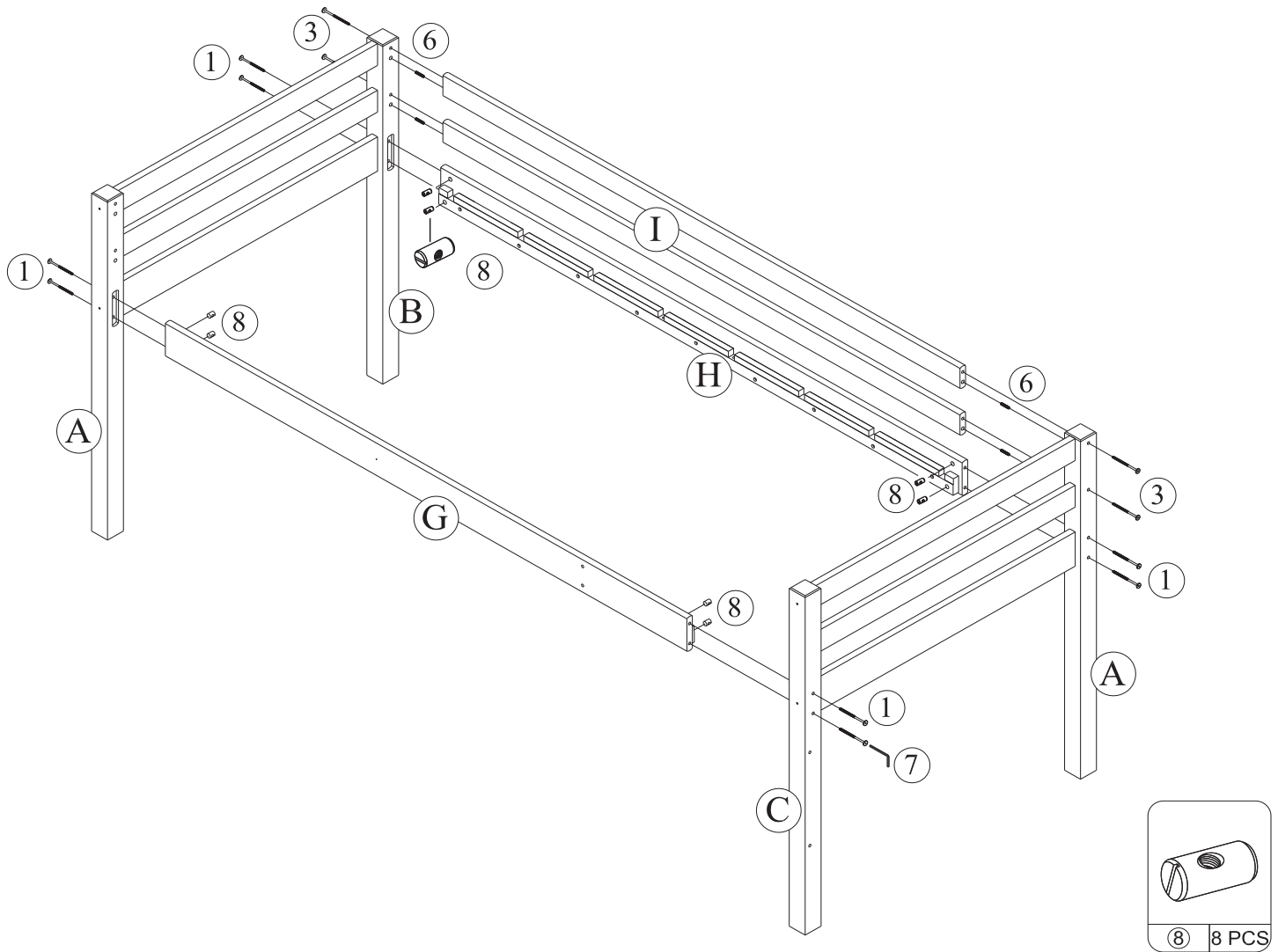

# JUNIOR TWIN LOFT BED

DA8377 / DA8377-E / DA8377-BL / DA8377-BK / DA8377-GR

## STEP 3

Insert two slats (L) into the center slots of the side rails (G) and (H) as shown below.

**NOTE:** Once the two (L) slats are inserted, there should be three empty spaces left on each side.

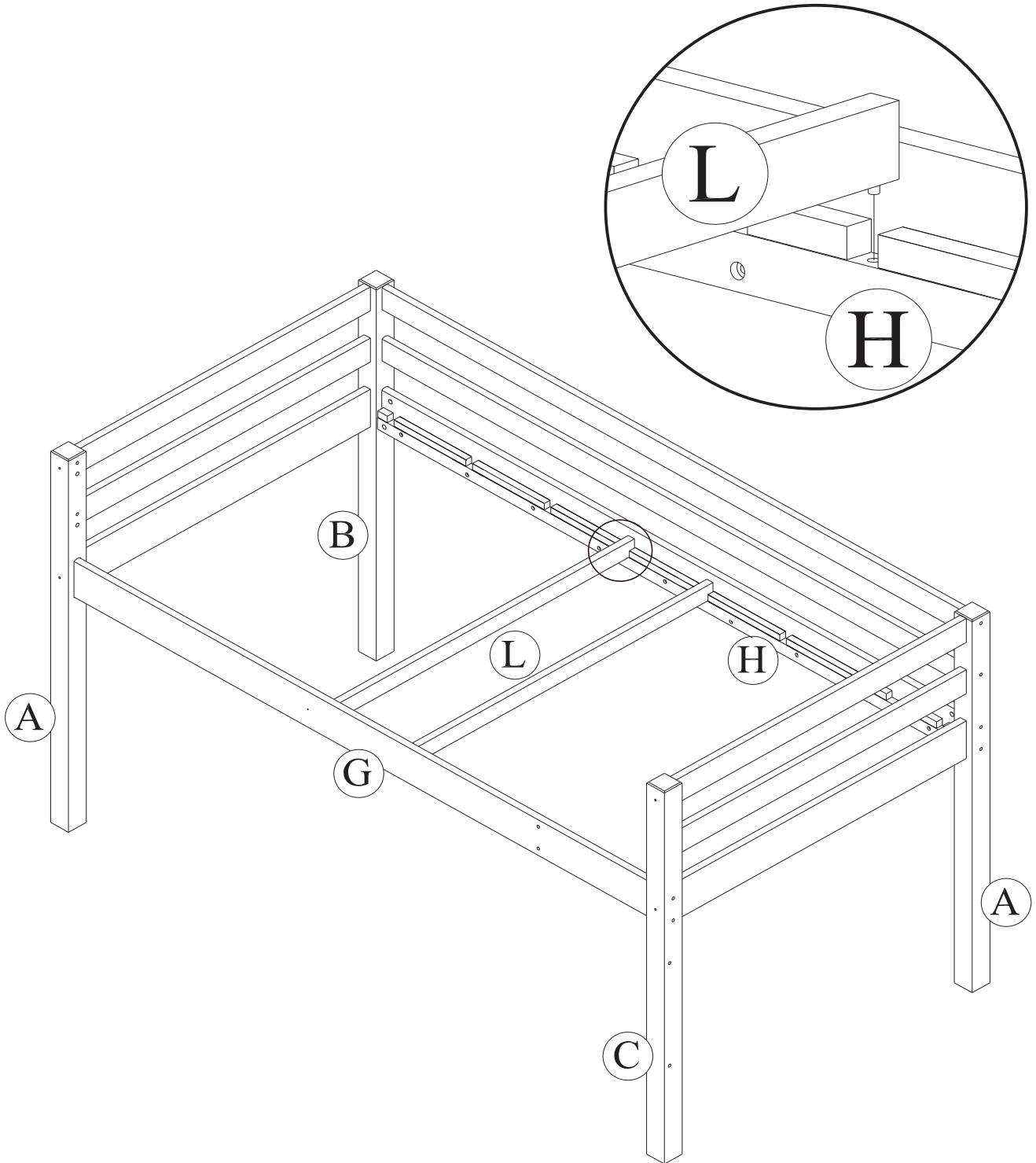

# JUNIOR TWIN LOFT BED

DA8377 / DA8377-E / DA8377-BL / DA8377-BK / DA8377-GR

## STEP 4

Insert slats (M) into remaining holes on the side rails (G) and (H).  
Secure slats (M) to the side rails (G) and (H) with flat head wood screws (4) using a Phillips-head screwdriver (not included).

**NOTE:** Slats (M) and (L) will be placed between two wooden blocks.

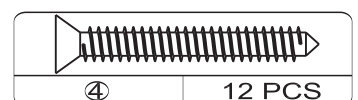
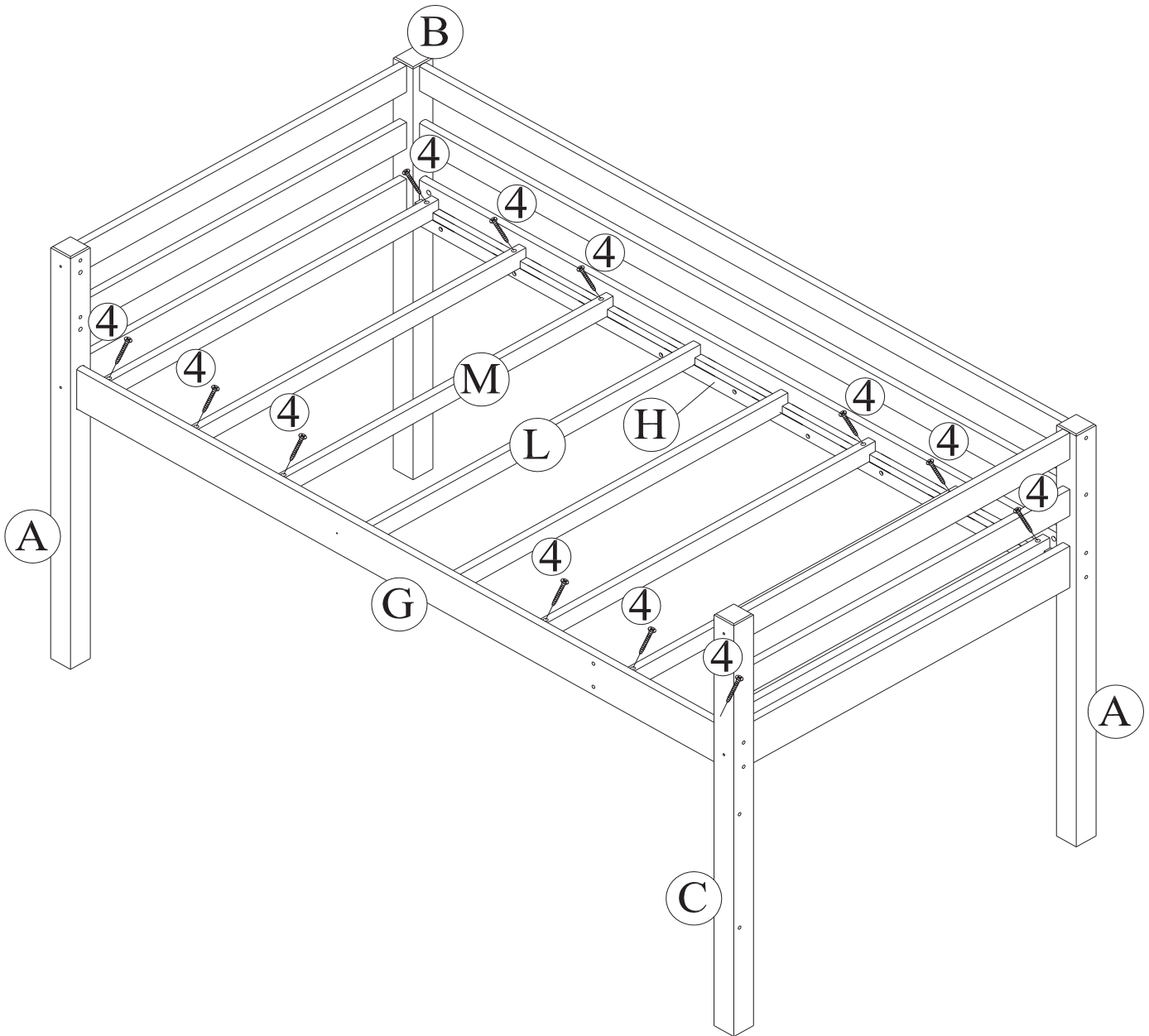

# JUNIOR TWIN LOFT BED

DA8377 / DA8377-E / DA8377-BL / DA8377-BK / DA8377-GR

## STEP 5

Insert wood dowels (6) in the ends of short guardrails (J). Attach short guardrails (J) to post (A) with wood joint connectors (3). Attach the guardrail leg (K) to the short guardrails (J) and side rail (G) with flat head wood screws (5). Attach the other guardrail leg (K) to the long guard rails (I) and side rail (H) with flat head wood screws (5).

Use a Phillips-head screwdriver (not included) to install screws (5).

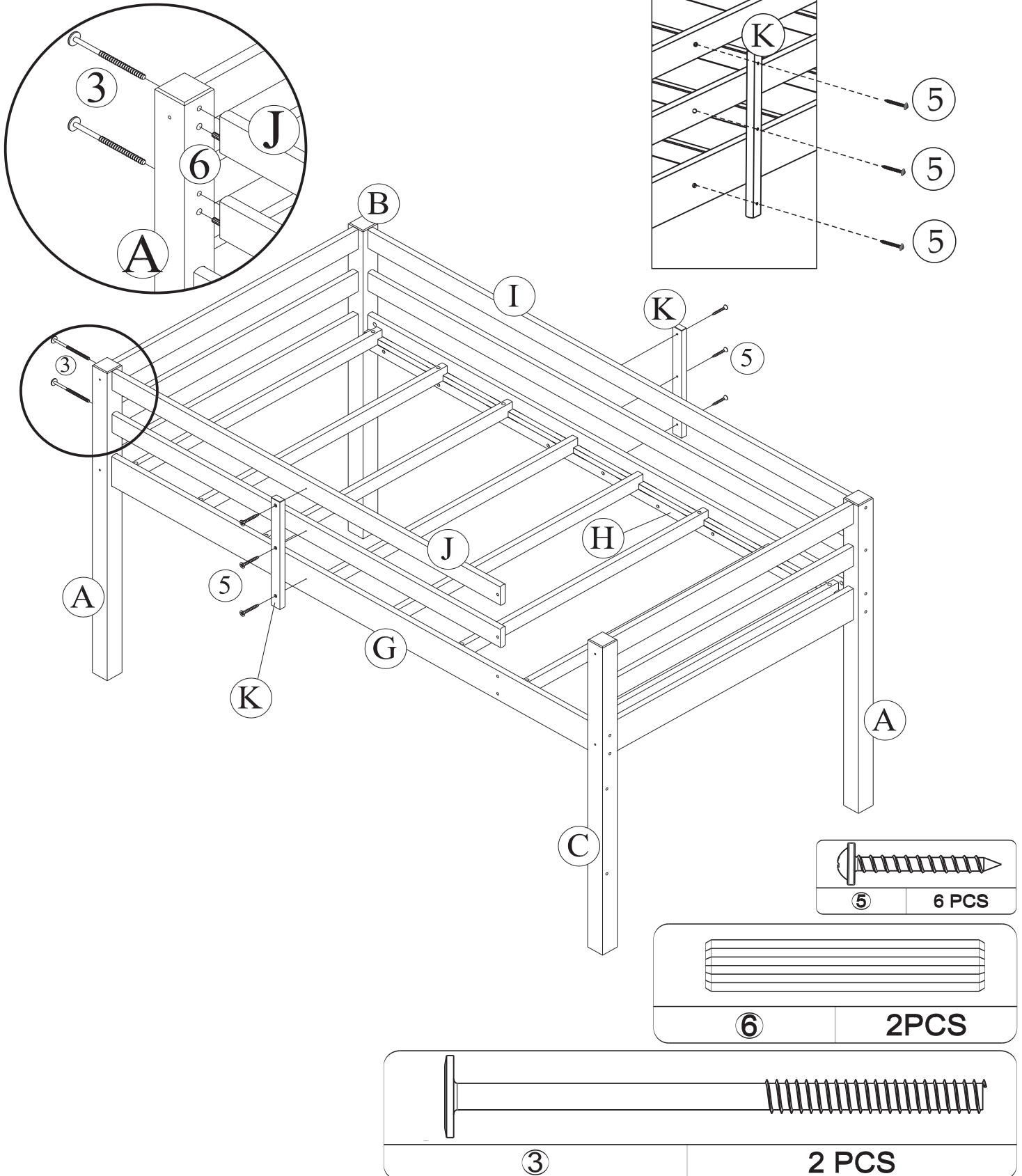

# JUNIOR TWIN LOFT BED

DA8377 / DA8377-E / DA8377-BL / DA8377-BK / DA8377-GR

## STEP 6

Insert wood dowels (6) into the ends of the ladder steps (O).

Attach ladder steps (O) to ladder end (N) with wood joint connectors (2) and to post (C) with wood joint connectors (3).

**NOTE:** Do not fully tighten the joint connectors. Loose joint connectors will facilitate assembly in the following steps.

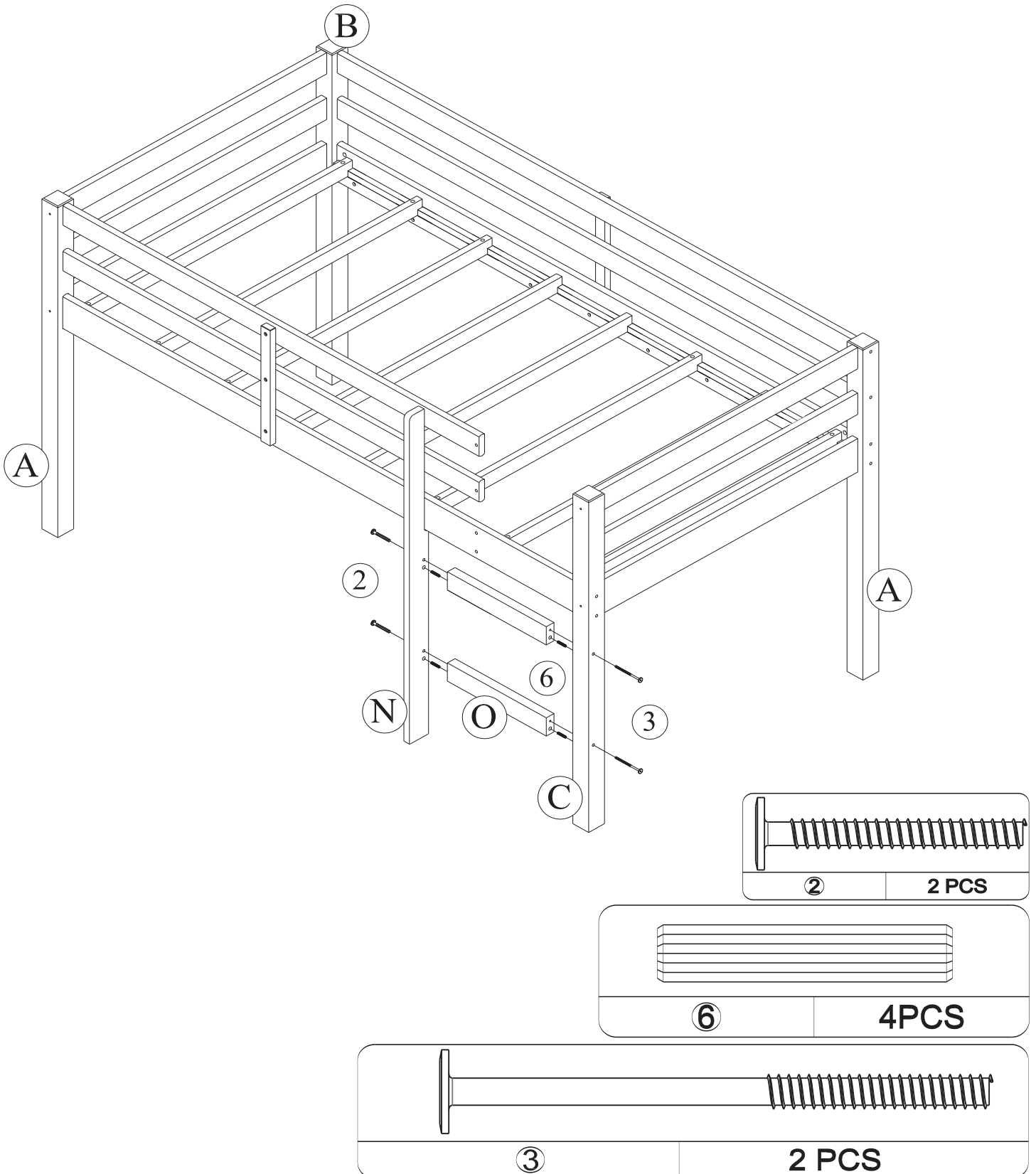

# JUNIOR TWIN LOFT BED

DA8377 / DA8377-E / DA8377-BL / DA8377-BK / DA8377-GR

## STEP 7

Attach the ladder to the short guardrails (J), the side rail (G) with wood joint connectors (2) as shown below.

Use Allen key (7) to tighten all the joint connectors previously installed.

**NOTE:** If slat (M) is covering the ladder mounting holes, temporarily remove slat (M) and place it after the ladder is attached

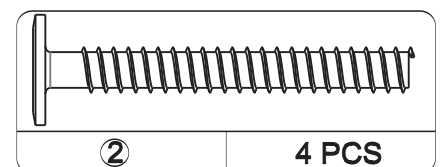
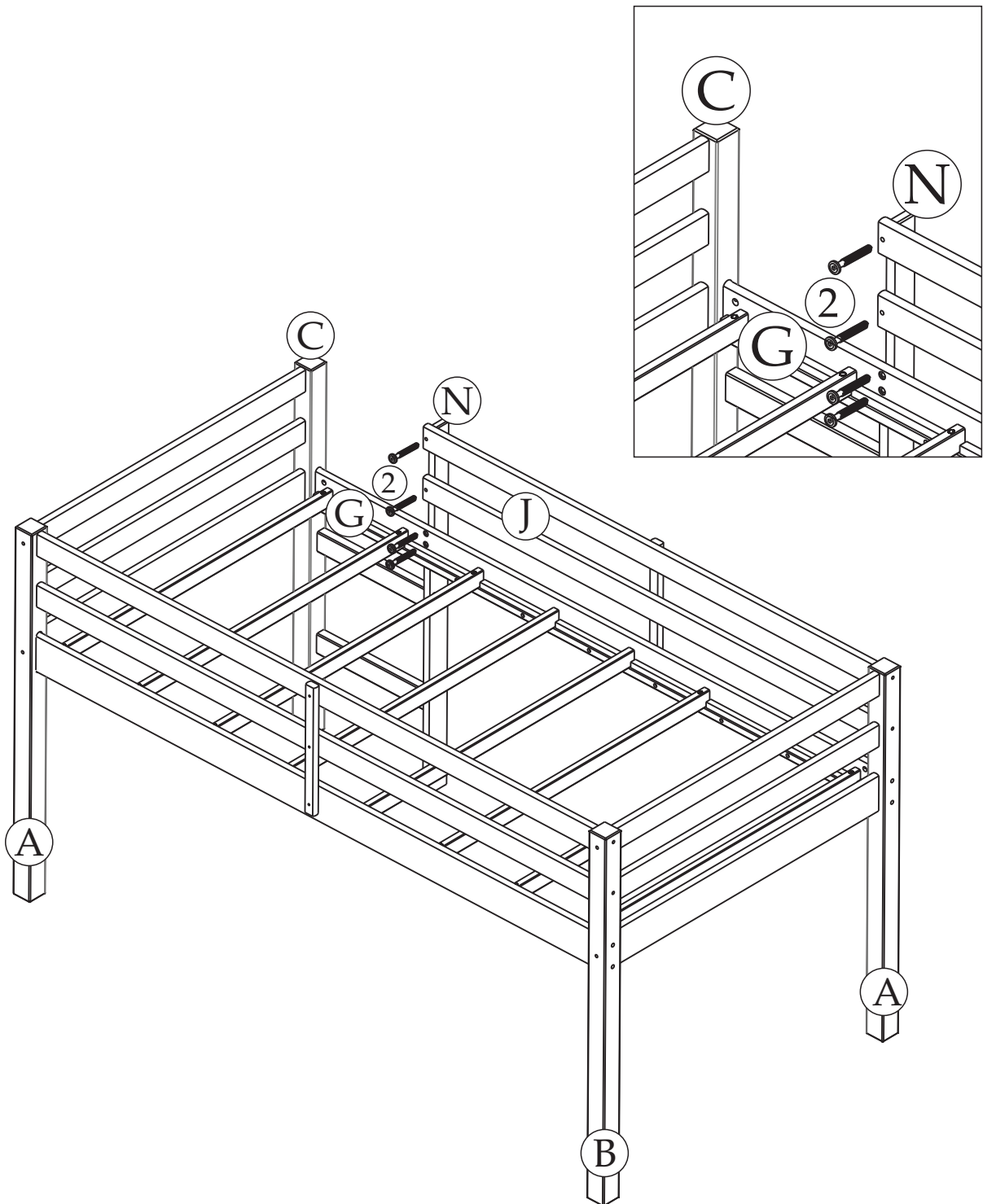

# JUNIOR TWIN LOFT BED

DA8377 / DA8377-E / DA8377-BL / DA8377-BK / DA8377-GR



**CAUTION:** This unit is intended for use only with the products and/or maximum weights indicated. Use with other products and/or products heavier than the maximum weights indicated may result in instability or cause possible injury.

**DO NOT ALLOW HORSEPLAY ON OR UNDER THE BED AND PROHIBIT JUMPING ON THE BED.**

**DO NOT ALLOW CHILDREN UNDER 4 YEARS OF AGE TO USE THE UPPER BUNK. BED IS DESIGNED FOR CHILDREN RANGING FROM 4 YEARS OF AGE TO TEENAGERS.**

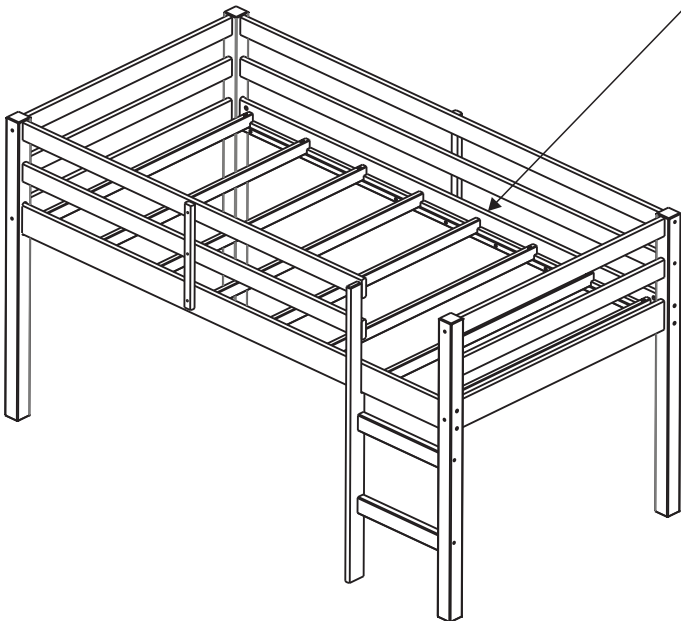

**MAXIMUM WEIGHT ON UPPER PART OF BED: 165 LBS / 75 KGS**

**USE ONLY COIL SPRING MATTRESSES ON THE UPPER BUNK. FAILURE TO DO SO CAN RESULT IN INJURY.**

**USE ONLY MATTRESSES WHICH ARE 74"-75" LONG AND 37 1/2" - 38 1/2" WIDE ON BED. ENSURE THICKNESS OF MATTRESS DOES NOT EXCEED 6".**

That's it! You've finished assembling your bunk bed.

**DO NOT RETURN PRODUCT TO THE STORE.**

If a part is missing or damaged, contact our customer service department. We will replace the part **FREE** of charge.

Tel #: 1-800-267-1739  
E-Mail: [cs@dhpffurniture.com](mailto:cs@dhpffurniture.com)



# CAMA LITERA JUNIOR LOFT INDIVIDUAL

Modelo No:	Código UPC:	Color:
DA8377	0-65857-19262-9	Blanco
DA8377-E	0-65857-19287-2	Espresso
DA8377-BL	0-65857-19907-9	Azul
DA8377-BK	0-65857-19908-6	Negro
DA8377-GR	0-65857-19909-3	Gris

¡Felicitaciones por su nueva compra de un mueble! Los muebles de la línea **Dorel Living** han sido diseñados con la calidad, la comodidad y el estilo en mente. Estamos seguros de que este mueble le servirá por muchos años con su comodidad excepcional.

Le recomendamos que antes de comenzar a armarlo se familiarice con su nueva compra y tome unos minutos de su tiempo para leer este manual. Contiene información importante sobre nuestra garantía y consejos de cuidados para que su mueble siempre conserve su apariencia de nuevo.

Para obtener más ideas de muebles inspirantes, visite nuestro sitio web en [www.dorelliving.com](http://www.dorelliving.com)

También puede mantenerse informado de todas las últimas tendencias suscribiéndose a nuestra página en [Facebook page](#) e [Instagram page](#).

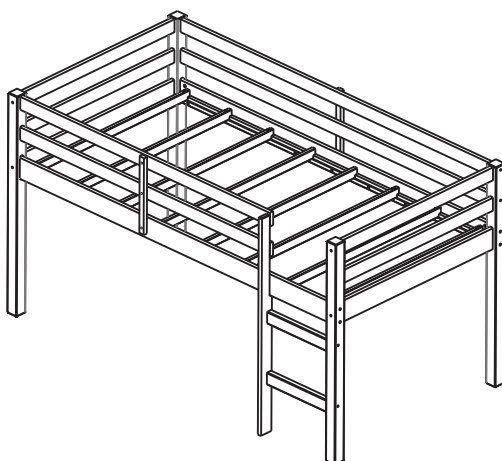

Fecha de compra: \_\_\_\_ / \_\_\_\_ / \_\_\_\_

Número de lote: \_\_\_\_\_  
(tomado del cartón)

Número del Manual de Instrucciones : B34DA837702-136832

Preguntas, inquietudes, partes que faltan? La satisfacción del cliente es importante para nosotros en Dorel Asia. **CONTACTE NUESTRO DEPARTAMENTO DE SERVICIO AL CLIENTE ANTES DE DEVOLVER EL PRODUCTO A LA TIENDA.**

**cs@dhpffurniture.com**

1-800-267-1739

Lunes - Viernes 9:00 am to 9:00 pm (hora del este)

Sábado 10 am to 6:30 pm (hora del este)

Domingo 11 am to 7 pm (hora del este)

**DHP Consumer Services**

12345 Albert Hudon, Suite 100,  
Montreal, Quebec, Canada H1G 3L1

**NOTA:** ESTE MANUAL DE INSTRUCCIONES CONTIENE INFORMACIÓN DE SEGURIDAD IMPORTANTE. POR FAVOR, LÉALO Y CONSÉRVELO PARA CONSULTARLO EN EL FUTURO.

## SERVICIO AL CLIENTE

También puede contactarnos escribiendo a la dirección que figura a continuación. Por favor incluya el número de modelo del producto, el color y una descripción detallada de su pregunta.

**DHP Consumer Services**  
**12345 Albert-Hudon Boulevard, Suite 100**  
**Montreal, Quebec**  
**Canada, H1G 3L1**

## NOTAS E INSTALACIÓN

- \* LEA ATENTAMENTE CADA ETAPA ANTES DE COMENZAR. ES MUY IMPORTANTE QUE CADA ETAPA SE LLEVE A CABO EN EL ORDEN CORRECTO. SI ESTAS ETAPAS NO SE SIGUEN EN ORDEN, PUEDEN SURGIR DIFICULTADES PARA ARMAR LA CAMA Y CAUSAR LESIONES A LOS NIÑOS QUE LA USAN.
- \* **ADVERTENCIA:** DEBE SER ARMADA POR UN ADULTO.
- \* ASEGÚRESE DE TENER TODAS LAS PIEZAS. TRABAJE EN UN LUGAR ESPACIOSO, DE PREFERENCIA SOBRE UNA SUPERFICIA LISA Y SUAVE.
- \* SE NECESITARÁN DOS PERSONAS PARA ARMARLA.
- \* LA MAYORÍA DE LAS PIEZAS DE MADERA ESTÁN ETIQUETADAS O MARCADAS DEL LADO RÚSTICO.
- \* SE NECESITA UN DESTORNILLADOR EN CRUZ (NO INCLUIDO).
- \* SE RECOMIENDA EL USO DE UNA MAZA DE CAUCHO (NO INCLUIDA) PARA FACILITAR EL TRABAJO DE ASAMBLAJE.
- \* LA CAMA ESTÁ DISEÑADA PARA NIÑOS DESDE 4 AÑOS HASTA LA ADOLESCENCIA TEMPRANA.

## CUIDADO, LIMPIEZA Y MANTENIMIENTO

Limpie regularmente con un paño suave y seco. No recomendamos el uso de limpiadores químicos o ceras en nuestros muebles laqueados, ya que pueden dañar el acabado. Mantenga los disolventes, el alcohol, el esmalte de uñas y los removedores de esmalte lejos de las superficies de sus muebles de madera.

Revise todos los pernos, tornillos y sujetadores periódicamente y apriételos si es necesario.

## GARANTÍA LIMITADA DE 1 AÑO

Dorel garantiza que este producto está libre de defectos de material y mano de obra y se compromete a remediar cualquier defecto de este tipo. Esta garantía cubre 1 año a partir de la fecha de compra original. Esta garantía es válida solamente con presentación de una prueba de compra. Esto se limita a la reparación o reemplazo de componentes defectuosos del mueble y no se incluye ningún trabajo de ensamblaje. Esta garantía no se aplica a ningún producto que haya sido mal ensamblado, sujeto a mal uso o abuso, o que haya sido alterado o reparado de cualquier manera. Cualquier uso, rotura o pérdida de color de la tela no están incluidos en esta garantía (donde corresponda). Esta garantía le da derechos legales específicas y usted puede también tener otros derechos que varían de estado a estado o de provincia a provincia.



**ADVERTENCIA: Si este producto está dañado y/o ciertas piezas faltan o están rotas, NO LO USE.**





## ADVERTENCIA

- \* **PELIGRO DE ESTRANGULAMIENTO** - NUNCA CUELGUE O ATE EN LA CAMA ARTÍCULOS QUE NO ESTÉN DISEÑADOS PARA USARLOS CON LA CAMA; POR EJEMPLO, PERO NO LIMITADO A ESTO, GANCHOS, CINTURONES Y CUERDAS DE SALTAR.
- \* SIGA LA INFORMACIÓN DE LAS ADVERTENCIAS INSCRITAS EN LA ESTRUCTURA DE LA CUCHETA SUPERIOR Y EN EL CARTÓN. NO RETIRE LA ETIQUETA DE ADVERTENCIAS DE LA CAMA.
- \* LA BASE DEL COLCHÓN ESTÁ DISEÑADA PARA SOPORTAR UN COLCHÓN SIN NECESIDAD DE USAR UNA TABLA PARA MANTENER LA POSICIÓN O UN SOPORTE CON RESORTES
- \* SIEMPRE UTILICE EL TAMAÑO DE COLCHÓN O DE SOPORTE DE COLCHÓN RECOMENDADO, O LOS DOS, PARA EVITAR LA POSIBILIDAD DE CAÍDAS O QUE EL NIÑO QUEDE ATRAPADO.
- \* **UTILICE SOLAMENTE COLCHONES CON RESORTES EN ESPIRAL EN LAS DOS CUCHETAS. EL NO RESPETAR ESTO PUEDE CAUSAR LESIONES.**
- \* UTILICE ÚNICAMENTE COLCHONES DE 188-191 CM (74"-75") DE LARGO Y 95-98 CM (37 1/2" - 38 1/2") DE ANCHO. ASEGÚRESE DE QUE EL ESPESOR DEL COLCHÓN NO EXCEDA 15 CM (6"). LA SUPERFICIE DEL COLCHÓN DEBE QUEDAR POR LO MENOS 5" (127MM) POR DEBAJO DEL BORDE SUPERIOR DEL MARCO DE LAS CUCHETAS.
- \* NO PERMITA QUE NIÑOS MENORES DE 4 AÑOS DUERMAN EN LA CUCHETA SUPERIOR.
- \* SIEMPRE UTILICE LAS BARANDAS EN LOS DOS LADOS DE LA CUCHETA SUPERIOR. SI LA CUCHETA ESTÁ COLOCADA AL LADO DE UNA PARED, LA BARANDA QUE CUBRE EL LADO LARGO DE LA CUCHETA DEBE SER COLOCADA CONTRA LA PARED PARA EVITAR QUE EL NIÑO QUEDE ATRAPADO ENTRE LA CAMA Y LA PARED (ESTO SE APLICA A LAS CUCHETAS CON BARANDA LARGA DE UN SOLO LADO).
- \* VERIFIQUE LA CAMA PERIÓDICAMENTE Y ASEGÚRESE DE QUE EL CUADRO, LA ESCALERILLA Y OTROS COMPONENTES ESTÉN EN LA POSICIÓN CORRECTA, NO ESTÉN DAÑADOS Y TODAS LAS UNIONES ESTÉN BIEN AJUSTADAS.
- \* NO PERMITA QUE LOS NIÑOS HAGAN PAYASADAS SOBRE O DEBAJO DE LA CAMA Y PROHIBA QUE SALTEN SOBRE ELLA.
- \* NO UTILICE PIEZAS DE SUSTITUCIÓN. CONTACTE EL SERVICIO AL CLIENTE PARA OBTENER PIEZAS PARA REMPLAZAR.
- \* EL USO DE UNA VELADORA SIRVE COMO MEDIDA DE PRECAUCIÓN PARA EL NIÑO QUE UTILIZA LA CUCHETA SUPERIOR.
- \* SE PROHIBE EL USO DE COLCHONES DE AGUA O COLCHONETAS DE FLOTACIÓN.
- \* SIEMPRE UTILICE LA ESCALERILLA PARA SUBIR A LA CUCHETA SUPERIOR O BAJAR DE ELLA.
- \* PROHIBA QUE MÁS DE UN NIÑO SUBA A LA CUCHETA SUPERIOR.
- \* CONSERVE ESTAS INSTRUCCIONES PARA REFERENCIA FUTURA.

**CAMA LITERA JUNIOR LOFT INDIVIDUAL**  
**DA8377 / DA8377-E / DA8377-BL / DA8377-BK / DA8377-GR**

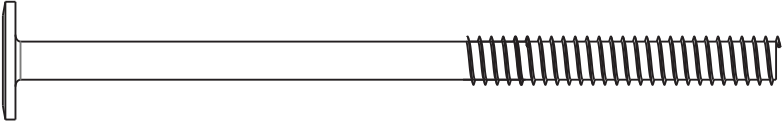
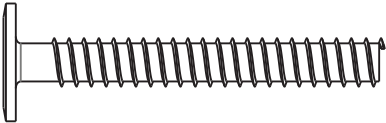
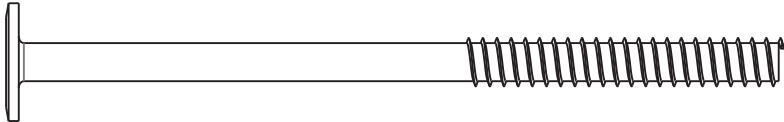
**LISTA DE ACCESORIOS**

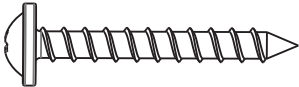
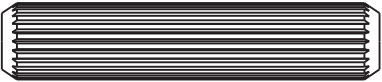
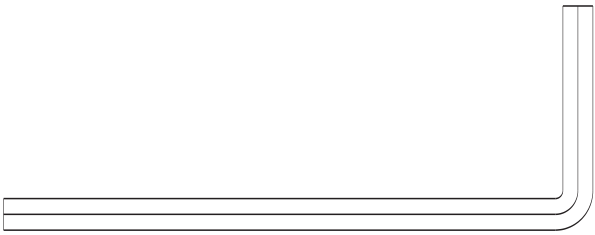
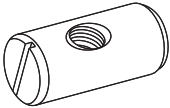
<p><b>1</b></p>  <p align="center">1/4" x 100mm            CONECTOR (4mm CABEZA HEX)            8 PZAS</p>	<p><b>2</b></p>  <p align="center">6.5mm x 48mm            CONECTOR PARA MADERA (4mm CABEZA HEX)            6 PZAS</p>
<p><b>3</b></p>  <p align="center">6.5mm x 100mm            CONECTOR PARA MADERA (4mm CABEZA HEX)            16 PZAS</p>	<p><b>4</b></p>  <p align="center">4mm x 35mm            TORNILLO PARA MADERA            12 PZAS</p>
<p><b>5</b></p>  <p align="center">4mm x 35mm            PERNO DE BRIDA            6 PZAS</p>	<p><b>6</b></p>  <p align="center">10mm x 50mm            CLAVIJA DE MADERA            34 PZAS</p>
<p><b>7</b></p>  <p align="center">LLAVE ALLEN            1 PZA</p>	<p><b>8</b></p>  <p align="center">11.8mm x 15mm            TUERCA BARRILETE            8 PZAS</p>

# CAMA LITERA JUNIOR LOFT INDIVIDUAL

## DA8377 / DA8377-E / DA8377-BL / DA8377-BK / DA8377-GR

### Paquete de componentes

# de Paquete :

DA8377-E (Espresso) DA8377-BL (Azul) DA8377-BK (Negro) DA8377-GR (Gris)	# de Paquete : <input checked="" type="checkbox"/> TDA8377-BK-00
DA8377 (Blanco)	# de Paquete : <input type="checkbox"/> TDA8377-00



**Nota:** Por favor no apriete completamente los pernos hasta que el ensamblaje sea completado, a menos de que se indique específicamente en cada paso de las instrucciones.





Los tornillo(s), perno(s) que se utilizan en cada paso se muestran en tamaño real en la esquina inferior derecha de cada página.

# CAMA LITERA JUNIOR LOFT INDIVIDUAL

DA8377 / DA8377-E / DA8377-BL / DA8377-BK / DA8377-GR

## LISTA DE PIEZAS

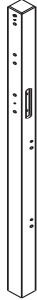
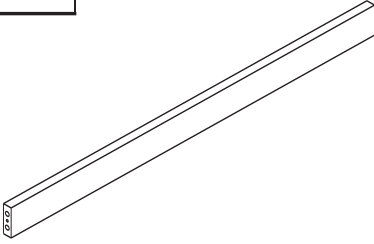
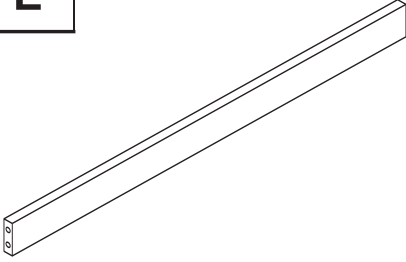
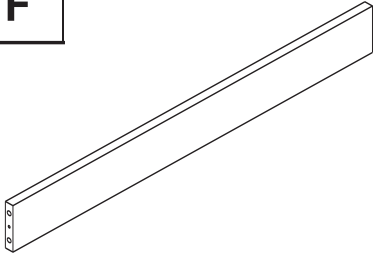

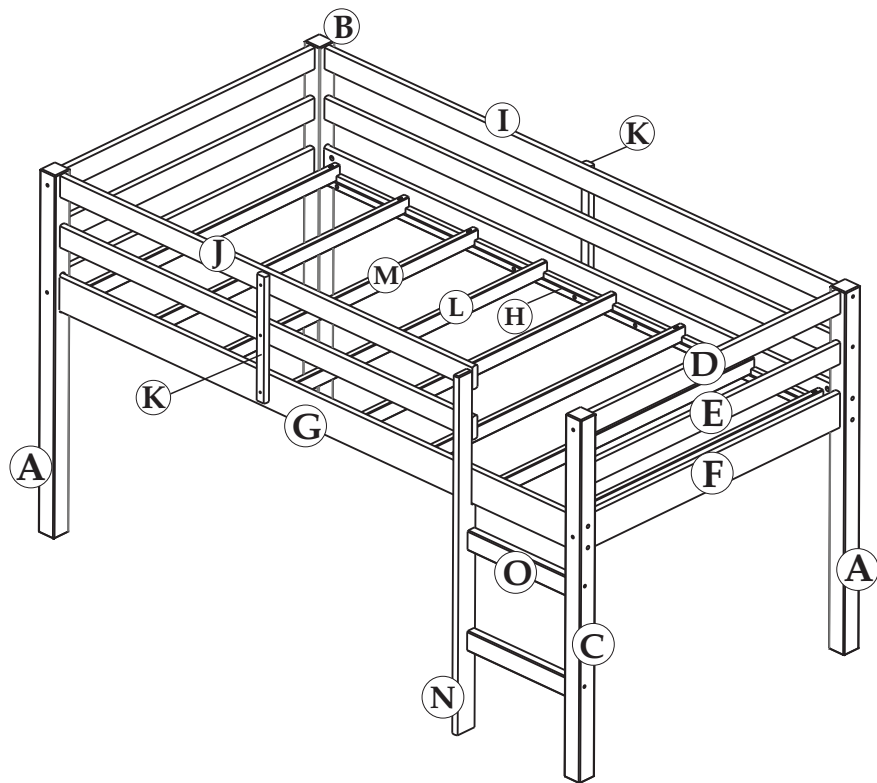

<p><b>A</b></p> 	<p><b>B</b></p> 	<p><b>C</b></p> 
<p>PATA 2 PZAS</p>	<p>PATA 1 PZA</p>	<p>PATA 1 PZA</p>
<p><b>D</b></p> 	<p><b>E</b></p> 	<p><b>F</b></p> 
<p>TRAVESAÑO SUPERIOR CABECERA 2 PZAS</p>	<p>TRAVESAÑO CENTRAL CABECERA 2 PZAS</p>	<p>TRAVESAÑO INFERIOR CABECERA 2 PZAS</p>

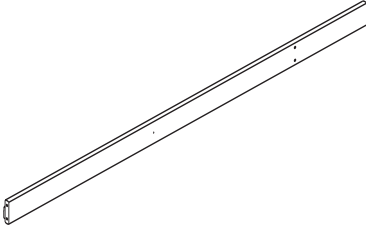
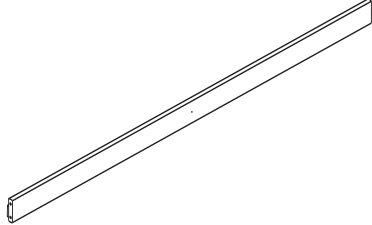
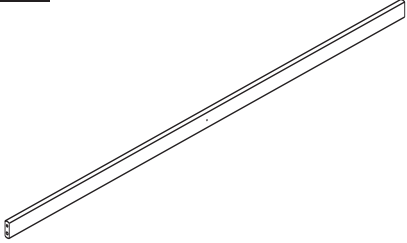
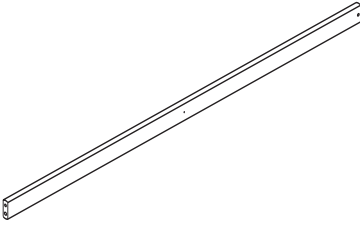

# CAMA LITERA JUNIOR LOFT INDIVIDUAL

DA8377 / DA8377-E / DA8377-BL / DA8377-BK / DA8377-GR

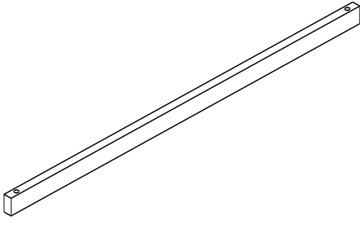
## LISTA DE PIEZAS

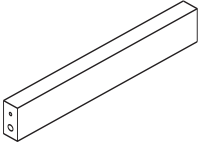
<p><b>G</b></p> 	<p><b>H</b></p> 	<p><b>I</b></p> 
<p>SOPORTE LATERAL (con 3 agujero) 1 PZA</p>	<p>SOPORTE LATERAL (con 1 agujero) 1 PZA</p>	<p>BARANDA LARGA 2 PZAS</p>
<p><b>J</b></p> 	<p><b>K</b></p> 	<p><b>L</b></p> 
<p>BARANDA CORTA 2 PZAS</p>	<p>SOPORTE BARANDA 2 PZAS</p>	<p>LISTÓN 2 PZAS</p>
<p><b>M</b></p> 	<p><b>N</b></p> 	<p><b>O</b></p> 
<p>LISTÓN 6 PZAS</p>	<p>EXTREMO DE LA ESCALERA 1 PZA</p>	<p>ESCALÓN 2 PZAS</p>

# CAMA LITERA JUNIOR LOFT INDIVIDUAL

## DA8377 / DA8377-E / DA8377-BL / DA8377-BK / DA8377-GR

### Partes

Piezas de reemplazo, visite [www.dhpfurniture.com/spa/replacement-parts](http://www.dhpfurniture.com/spa/replacement-parts)

**IMPORTANTE:** La lista de números de piezas que aparece a continuación es exclusiva de su producto. Por favor, manténgalo a mano cuando solicite piezas de repuesto.



*Antes de deshacerse de las cajas de cartón, asegúrese de que estén vacías. También confirme que ha recibido todos los componentes necesarios para el ensamblaje al compararlos con la tabla de piezas indicadas en la sección en inglés.*

NÚMERO DE PIEZAS					
ETIQUETAS DE PIEZAS	DA8377 (Blanco)	DA8377-E (Espresso )	DA8377-BL (Azul)	DA8377-BK (Negro)	DA8377-GR (Gris)
A	T995720	T995870	T996020	T996170	T996320
B	T995730	T995880	T996030	T996180	T996330
C	T995740	T995890	T996040	T996190	T996340
D	T995750	T995900	T996050	T996200	T996350
E	T995760	T995910	T996060	T996210	T996360
F	T995770	T995920	T996070	T996220	T996370
G	T995780	T995930	T996080	T996230	T996380
H	T995790	T995940	T996090	T996240	T996390
I	T995800	T995950	T996100	T996250	T996400
J	T995810	T995960	T996110	T996260	T996410
K	T995820	T995970	T996120	T996270	T996420
L	T995830	T995980	T996130	T996280	T996430
M	T995840	T995990	T996140	T996290	T996440
N	T995850	T996000	T996150	T996300	T996450
O	T995860	T996010	T996160	T996310	T996460



# CAMA LITERA JUNIOR LOFT INDIVIDUAL

## DA8377 / DA8377-E / DA8377-BL / DA8377-BK / DA8377-GR

### ETAPA 1

Una de los travesaños superiores de la cabecera (D) tiene una etiqueta, úsela en este paso.

Inserte clavijas de madera (6) en los travesaños superiores de la cabecera (D), los travesaños inferiores de la cabecera (F) y los travesaños central de la cabecera (E).

Conecte los cruces de madera prensada (D, F, E) a los postes (A) y (B) usando los conectores de unión de madera (3) como se muestra a continuación.

Use la llave Allen (7) para apretar los conectores de la junta de madera.

Repita el paso anterior para ensamblar la otra cabecera usando los postes inferiores (C) y (A).

**NOTA:** Ajuste los travesaños de la cabecera (D, F, E) para permitir que las clavijas de madera (6) se alineen con los agujeros en los postes (A) y (B).

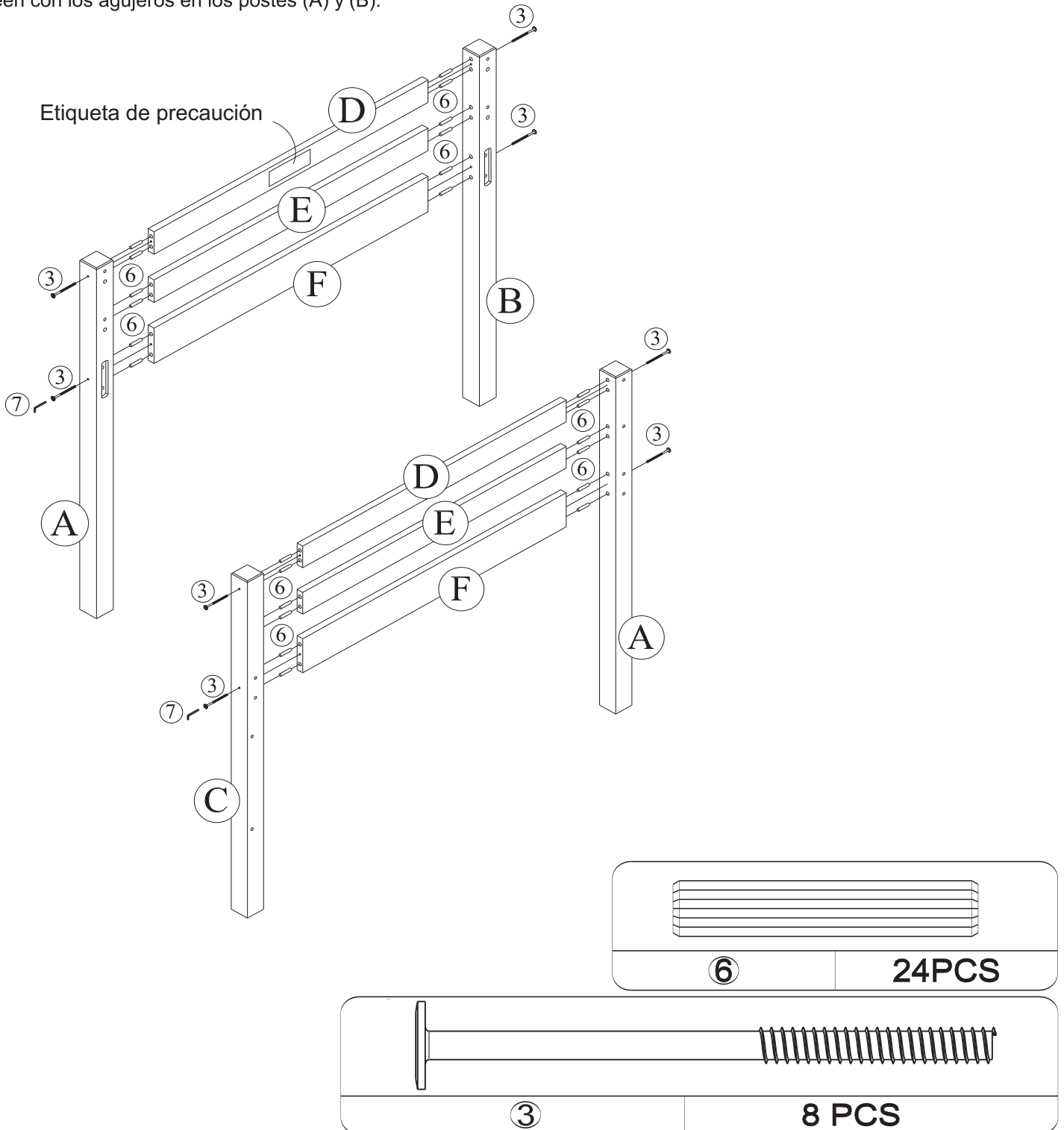

# CAMA LITERA JUNIOR LOFT INDIVIDUAL

## DA8377 / DA8377-E / DA8377-BL / DA8377-BK / DA8377-GR

### ETAPA 2

Inserte las clavijas de madera (6) en cada extremo de las barandillas largas (I). Una las barandas largas (I) y las barandas laterales (G) y (H) a los postes (A & B) y (A & C) como se muestra a continuación.

Sujete los rieles laterales (G) y (H) con los conectores (1) y las tuercas barrilete (8). Sujete las barandas largas (I) con los conectores de madera (3).

Use la llave Allen (7) para apretar todos los conectores.

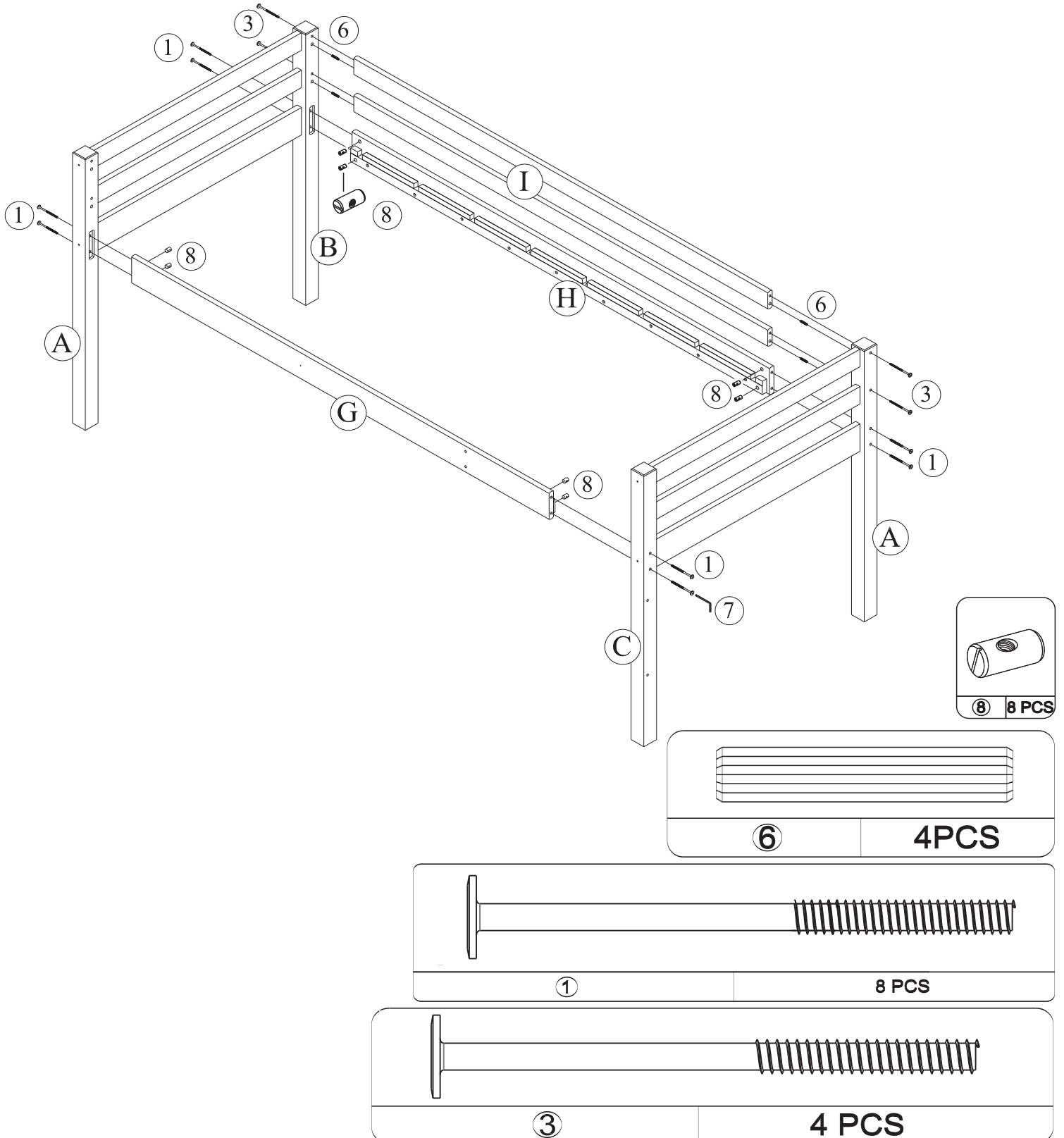

# CAMA LITERA JUNIOR LOFT INDIVIDUAL

DA8377 / DA8377-E / DA8377-BL / DA8377-BK / DA8377-GR

## ETAPA 3

Inserte dos listones (L) en las ranuras centrales de los soportes laterales (G) y (H) como se muestra a continuación.

**NOTA:** una vez que se insertan los dos listones (L), deben quedar tres espacios vacíos a cada lado.

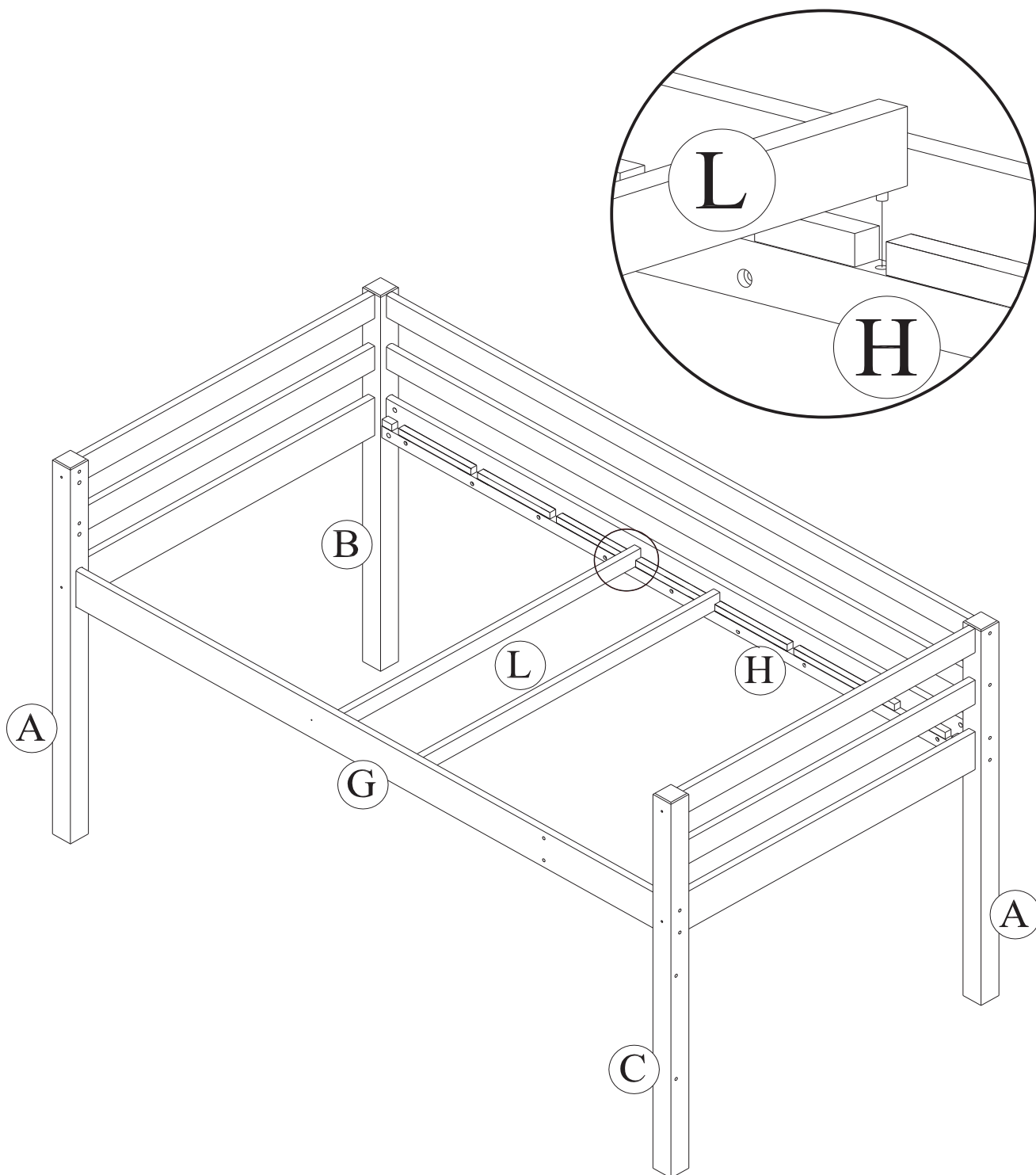

# CAMA LITERA JUNIOR LOFT INDIVIDUAL

DA8377 / DA8377-E / DA8377-BL / DA8377-BK / DA8377-GR

## ETAPA 4

Inserte los listones (M) en los agujeros restantes de los soportes laterales (G) y (H).

Asegure los listones (M) a los soportes laterales (G) y (H) con los tornillos de madera (4) con la ayuda de un destornillador Phillips (no incluido).

**NOTA:** Los listones (M) y (L) se colocarán entre dos bloques de madera.

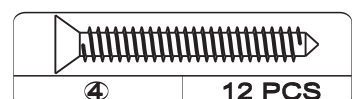
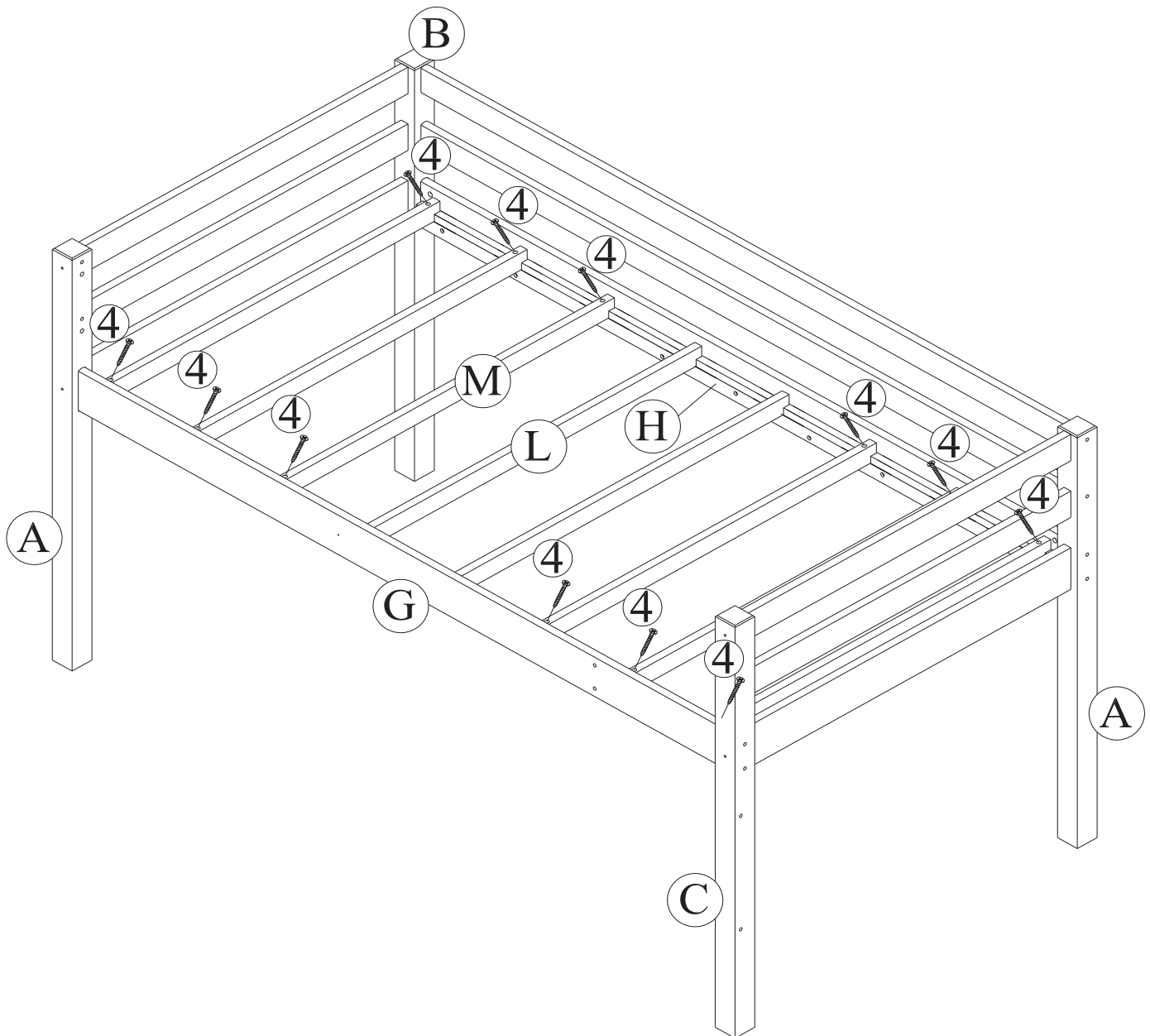

# CAMA LITERA JUNIOR LOFT INDIVIDUAL

## DA8377 / DA8377-E / DA8377-BL / DA8377-BK / DA8377-GR

### ETAPA 5

Inserte las clavijas de madera (6) en los extremos de las barandas cortas (J). Conecte las barandas cortas (J) al poste (A) con los conectores de madera (3). Coloque el soporte de baranda (K) en las barandas cortas (J) y en la baranda lateral (G) con los tornillos para madera (5). Conecte el otro soporte de baranda (K) a las barandas largas (I) y al soporte lateral (H) con los tornillos para madera (5). Use un destornillador Phillips (no incluido) para instalar los tornillos (5).

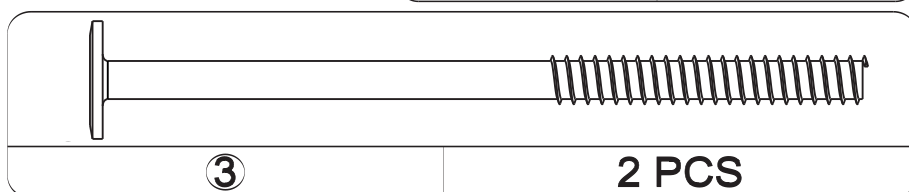
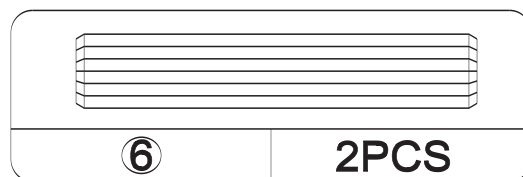
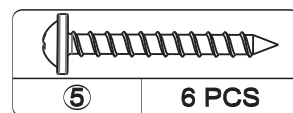
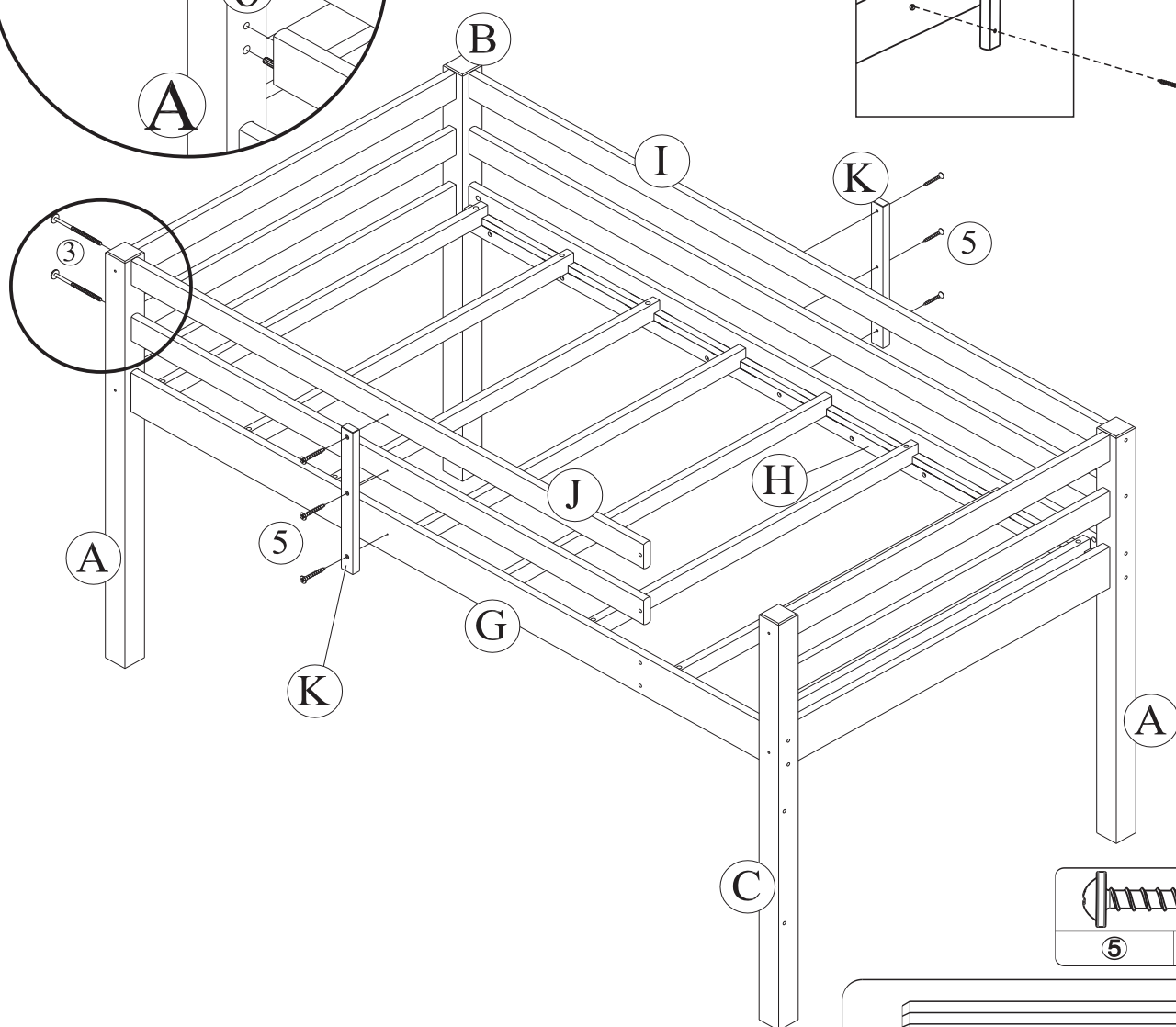
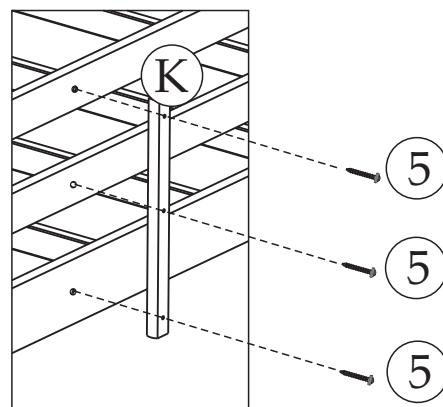
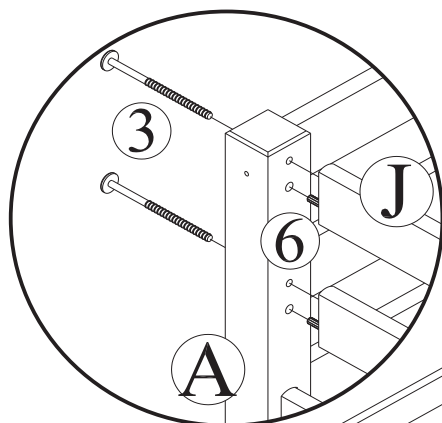

# CAMA LITERA JUNIOR LOFT INDIVIDUAL

DA8377 / DA8377-E / DA8377-BL / DA8377-BK / DA8377-GR

## ETAPA 6

Inserte clavijas de madera (6) en los extremos de los escalones de la escalera (O).

Fije los escalones de la escalera (O) al extremo de la escalera (N) con los conectores de madera (2) y al poste (C) con los conectores de madera (3).

**NOTA:** No apriete completamente los conectores, al estar sueltos facilitarán el montaje en los siguientes pasos.

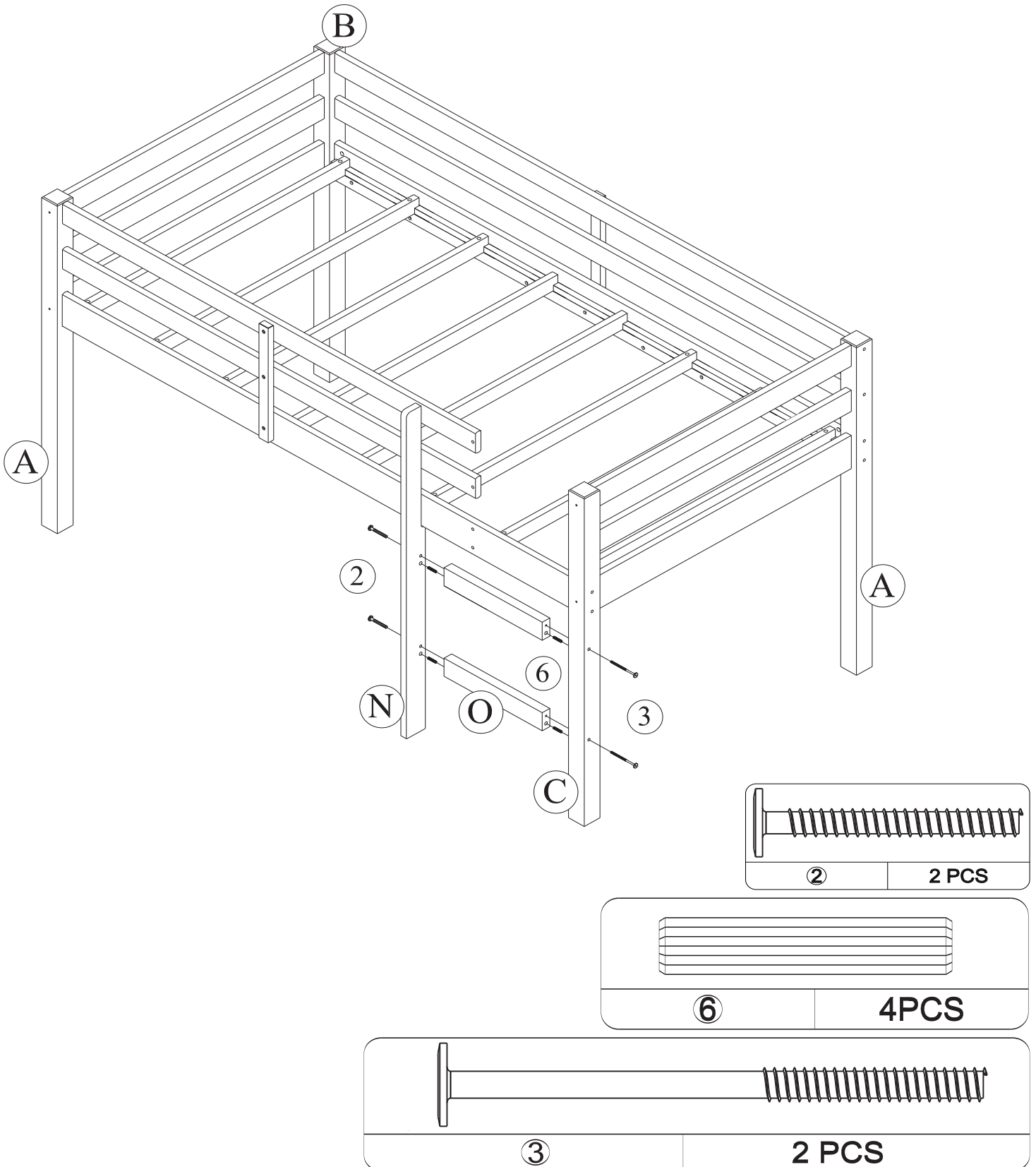

# CAMA LITERA JUNIOR LOFT INDIVIDUAL

DA8377 / DA8377-E / DA8377-BL / DA8377-BK / DA8377-GR

## ETAPA 7

Sujete la escalera a las barandas cortas (J), la baranda lateral (G) con los conectores de madera (2) como se muestra a continuación.

Use la llave Allen (7) para apretar todos los conectores instalados previamente.

**NOTA:** Si el listón (M) está cubriendo los orificios de montaje de la escalera, quite el listón (M) temporalmente (M) e insertelo después de colocar la escalera.

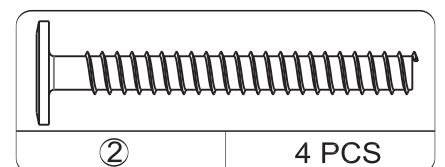
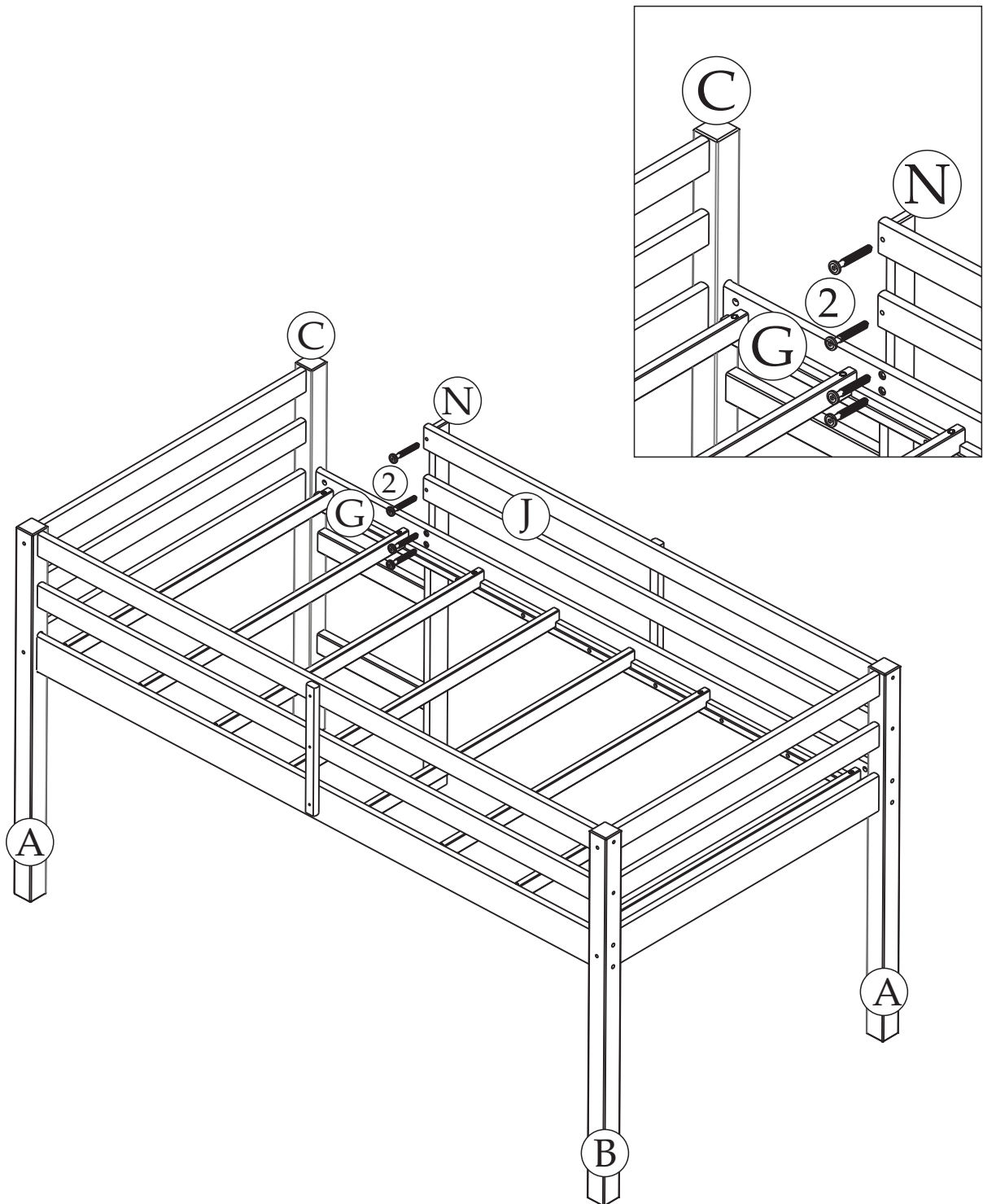

# CAMA LITERA JUNIOR LOFT INDIVIDUAL

DA8377 / DA8377-E / DA8377-BL / DA8377-BK / DA8377-GR



**PRECAUCIÓN:** Esta unidad está diseñada para ser utilizada únicamente con los productos y/o pesos máximos indicados. Su uso con otros productos y/o productos más pesados que los pesos máximos indicados puede provocar inestabilidad o causar lesiones.

**NO PERMITA QUE LOS NIÑOS HAGAN PAYASADAS SOBRE O DEBAJO DE LA CAMA Y PROHIBA QUE SALTEN SOBRE ELLA.**

**NO PERMITA QUE NIÑOS MENORES DE 4 AÑOS DUERMAN EN LA CUCHETA SUPERIOR. LA CAMA ESTÁ DISEÑADA PARA NIÑOS DESDE 4 AÑOS HASTA LA ADOLESCENCIA TEMPRANA.**

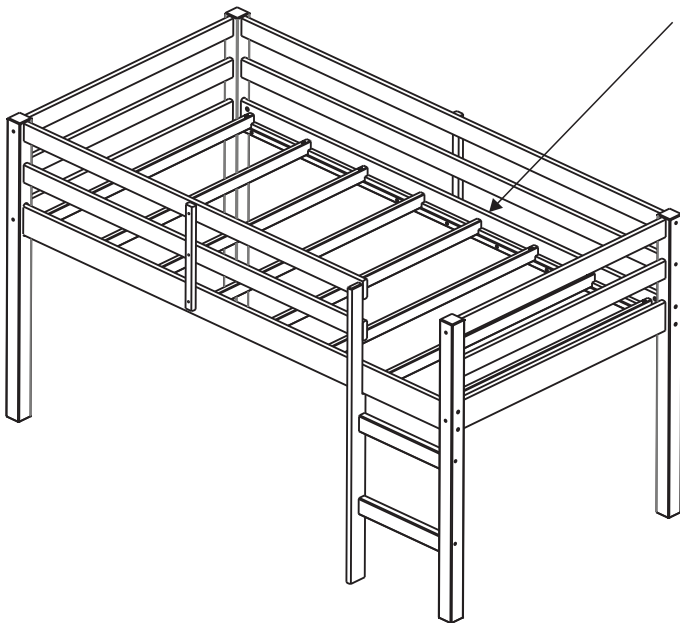

**PESO MÁXIMO : 165 LBS / 75 KGS**

**UTILICE SOLAMENTE COLCHONES CON RESORTES EN ESPIRAL EN LA CAMA LITERA. EL NO RESPETAR ESTO PUEDE CAUSAR LESIONES.**

**UTILICE ÚNICAMENTE COLCHONES DE 188-191 CM (74"-75") DE LARGO Y 95-98 CM (37 1/2" - 38 1/2") DE ANCHO. ASEGÚRESE DE QUE EL ESPESOR DEL COLCHÓN NO EXCEDA 15 CM (6").**

Listo! Ha terminado de ensamblar su cama litera.

**NO DEVUELVA EL PRODUCTO A LA TIENDA.** Si falta una pieza o está dañada, comuníquese con nuestro Departamento de Servicio al Cliente.

Reemplazaremos la pieza SIN costo alguno

TÉL. # : 1-800-267-1739

Correo electronico [cs@dhpffurniture.com](mailto:cs@dhpffurniture.com)



# LIT MEZZANINE JUNIOR SIMPLE

Modèle No:	Code UPC:	Couleur:
DA8377	0-65857-19262-9	Blanc
DA8377-E	0-65857-19287-2	Espresso
DA8377-BL	0-65857-19907-9	Bleu
DA8377-BK	0-65857-19908-6	Noir
DA8377-GR	0-65857-19909-3	Gris

Félicitations pour votre dernier achat d'un meuble ! Les meubles de la ligne **Dorel Living** ont été conçus ayant en tête la qualité, la commodité et le style. Nous sommes convaincus que ce meuble vous servira durant de nombreuses années avec un confort exceptionnel.

Nous vous encourageons à vous familiariser avec les caractéristiques de votre nouveau meuble avant de commencer l'assemblage ; prenez donc quelques minutes pour lire ce manuel. Il contient de l'information importante concernant notre garantie et des conseils d'entretien pour vous assurer de garder votre meuble aussi beau qu'aux premiers jours.

Pour trouver d'autres idées inspirantes, veuillez visiter notre site web à [www.dorelliving.com](http://www.dorelliving.com)  
Vous pouvez aussi souscrire à notre page **Facebook** pour être à la fine pointe de toutes les dernières tendances.  
et **Instagram page**.

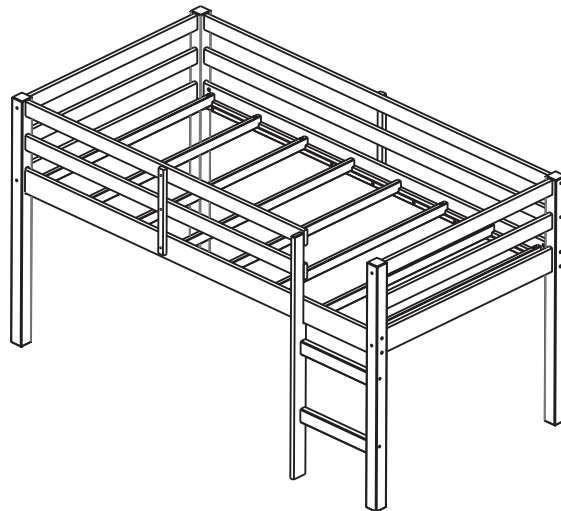

Date d'achat: \_\_\_\_ / \_\_\_\_ / \_\_\_\_

Numéro de lot: \_\_\_\_\_  
(sur la boîte)

Numéro du Manuel d'Instructions : B34DA837702-136832

Des questions, des préoccupations, des pièces manquantes? La satisfaction du client est importante pour nous chez Dorel Asia. **CONTACTEZ NOTRE SERVICE À LA CLIENTÈLE AVANT DE RETOURNER LE PRODUIT AU DÉTAILLANT.**

**cs@dhpffurniture.com**

1-800-267-1739

Lundi - Vendredi 9:00 am to 9:00 pm (Heure de l'Est)

Samedi 10 am to 6:30 pm (Heure de l'Est)

Dimanche 11 am to 7 pm (Heure de l'Est)

**DHP Consumer Services**

12345 Albert Hudon, Suite 100,  
Montreal, Quebec, Canada H1G 3L1

**NOTE: CE MANUEL D'INSTRUCTIONS CONTIENT INFORMATION DE SÉCURITÉ IMPORTANTE. VEUILLEZ LE LIRE ET LE CONSERVER POUR RÉFÉRENCE ULTÉRIEURE.**

## SERVICE À LA CLIENTÈLE

Vous pouvez également nous contacter en écrivant à l'adresse ci-dessous. S'il vous plaît inclure le numéro de modèle du produit, la couleur et une description détaillée de votre demande.

**DHP Consumer Services**  
**12345 Albert-Hudon Boulevard, Suite 100**  
**Montreal, Québec**  
**Canada, H1G 3L1**

## NOTES ET INSTALLATION

- \* LIRE ATTENTIVEMENT CHAQUE ÉTAPE AVANT DE COMMENCER. IL EST TRÈS IMPORTANT QUE CHAQUE ÉTAPE SOIT EXÉCUTÉE DANS L'ORDRE APPROPRIÉ. SI CES ÉTAPES NE SONT PAS SUIVIES DANS L'ORDRE, DES DIFFICULTÉS D'ASSEMBLAGE SE PRODUIRONT ET PEUVENT ENTRAÎNER DES BLESSURES.
- \* **ATTENTION:** ASSEMBLAGE PAR UN ADULTE REQUIS.
- \* ASSUREZ-VOUS QUE TOUTES LES PIÈCES SONT INCLUSES. TRAVAILLEZ DANS UN ENDROIT SPACIEUX, PRÉFÉRABLEMENT SUR UNE SURFACE LISSE ET DOUCE.
- \* DEUX PERSONNES SONT REQUISES POUR L'ASSEMBLAGE.
- \* LA PLUPART DES PLANCHES SONT ÉTIQUETÉES OU ESTAMPILLÉES SUR LE CÔTÉ NON-FINI.
- \* UN TOURNEVIS À TÊTE CRUCIFORME (NON INCLUS) EST NÉCESSAIRE.
- \* UN MAILLET EN CAOUTCHOUC (NON INCLUS) EST RECOMMANDÉ POUR FACILITER L'ASSEMBLAGE.
- \* LE LIT EST CONÇU POUR DES ENFANTS DE 4 ANS JUSQU'À JEUNES ADOLESCENTS.

## SOIN, NETTOYAGE ET ENTRETIEN

Époussetez régulièrement avec un chiffon doux et sec. Nous ne recommandons pas l'utilisation de produits nettoyants ou de cire sur notre mobilier laqué car cela pourrait endommager la finition. Gardez les solvants, alcools, vernis à ongles et décapants loin des surfaces de votre mobilier en bois franc. Utilisez un service de nettoyage professionnel pour nettoyer le tissu.

Vérifiez régulièrement tous les boulons, vis et fixations et serrez-les si nécessaire.

## GARANTIE LIMITÉE DE 1 AN

Dorel garantit que son produit est exempt de défauts de matériaux et de fabrication et accepte de remédier à un tel défaut. Cette garantie couvre un (1) an à partir de la date d'achat originale. Cette garantie est valable uniquement sur présentation d'une preuve d'achat. Cette garantie se limite exclusivement à la réparation ou au remplacement de pièces défectueuses du mobilier et aucun travail d'assemblage n'est inclus. Cette garantie ne s'applique pas à un produit qui a été assemblé incorrectement, soumis à une mauvaise utilisation ou abus, ou qui a été modifié ou réparé de quelque façon. L'usure, les déchirures ou la décoloration du tissu ne sont pas couverts par cette garantie (le cas échéant). Cette garantie vous donne des droits légaux spécifiques et vous pouvez également avoir d'autres droits qui varient d'un État à l'autre ou d'une province à l'autre.



**AVERTISSEMENT: Si ce produit est endommagé, et/ou des pièces sont brisées ou manquantes, NE PAS UTILISER.**







## MISE EN GARDE

- \* **DANGER D'ÉTRANGLEMENT** – NE JAMAIS ATTACHER OU SUSPENDRE D'ARTICLES SUR AUCUNE PARTIE DU LIT SUPERPOSÉ QUI NE SONT PAS CONÇUS POUR ÊTRE UTILISÉ AVEC LE LIT; PAR EXEMPLE, MAIS NE SE LIMITANT PAS À DES CROCHETS, CEINTURES ET CORDES À DANSER.
- \* SUIVEZ LES INFORMATIONS SUR LES MISES EN GARDE INSCRITES SUR LA STRUCTURE DU LIT SUPERPOSÉ SUPÉRIEUR ET SUR LA BOÎTE. NE PAS ENLEVER L'ÉTIQUETTE DE MISE EN GARDE SUR LE LIT.
- \* LA PLATEFORME DE MATELAS EST CONÇUE POUR SUPPORTER UN MATELAS SANS AVOIR BESOIN D'UN SUPPORT DE MATELAS OU D'UN SOMMIER.
- \* TOUJOURS UTILISER LE FORMAT DE MATELAS OU DE SUPPORT DE MATELAS RECOMMANDÉ, OU LES DEUX, POUR AIDER À PRÉVENIR LES RISQUES PROBABLES DE PIÉGAGE OU DE CHUTES.
- \* **UTILISEZ UNIQUEMENT DES MATELAS À RESSORTS. SINON DES BLESSURES PEUVENT EN RÉSULTER.**
- \* UTILISEZ UNIQUEMENT DES MATELAS DE 188-191 CM (74"-75") DE LONG PAR 95-98 CM (37 1/2" - 38 1/2") DE LARGE . ASSUREZ-VOUS QUE L'ÉPAISSEUR DU MATELAS N'EXCÈDE PAS 6" (15 CM). LA SURFACE DU MATELAS DOIT ÊTRE À ENVIRON 5" (12.7CM) EN DESSUS DU BORD SUPÉRIEUR DES BARRIÈRES DE LIT.
- \* NE PAS PERMETTRE AUX ENFANTS DE MOINS DE 4 ANS D'UTILISER LE LIT SUPÉRIEUR.
- \* TOUJOURS UTILISER LES BARRIÈRES SUR LES DEUX CÔTÉS LONGS DU LIT SUPÉRIEUR. SI LE LIT SUPERPOSÉ SERA PLACÉ À CÔTÉ D'UN MUR. LA BARRIÈRE DE LA PLEINE GRANDEUR DU LIT DOIT ÊTRE PLACÉE CONTRE LE MUR POUR PRÉVENIR LES RISQUES DE PIÉGAGE ENTRE LE LIT ET LE MUR (APPLICABLE POUR LES LITS SUPERPOSÉS AVEC BARRIÈRES PLEINE LONGUEUR SUR UN CÔTÉ).
- \* VÉRIFIEZ PÉRIODIQUEMENT ET ASSUREZ-VOUS QUE LA BARRIÈRE, L'ÉCHELLE ET LES AUTRES COMPOSANTS SONT EN PLACE CORRECTEMENT, SANS DOMMAGES, ET QUE TOUTES LES VIS DE RACCORDEMENT SONT BIEN SERRÉES.
- \* NE PAS JOUER SUR OU SOUS LE LIT ET INTERDICTION DE SAUTER SUR LE LIT.
- \* NE PAS SUBSTITUER DE PIÈCES. CONTACTEZ LE SERVICE À LA CLIENTÈLE POUR DES PIÈCES DE REMPLACEMENT.
- \* L'UTILISATION D'UNE VEILLEUSE REPRÉSENTE UNE PRÉCAUTION DE SÉCURITÉ SUPPLÉMENTAIRE POUR L'ENFANT QUI OCCUPE LE LIT SUPÉRIEUR.
- \* L'UTILISATION D'UN MATELAS D'EAU OU MATELAS GONFLABLE EST INTERDITE.
- \* TOUJOURS UTILISER L'ÉCHELLE POUR MONTER OU DESCENDRE DU LIT SUPÉRIEUR.
- \* INTERDIRE PLUS D'UNE PERSONNE SUR LE LIT SUPÉRIEUR.
- \* CONSERVEZ CES INSTRUCTIONS POUR RÉFÉRENCE ULTÉRIEURE.

# LIT MEZZANINE JUNIOR SIMPLE

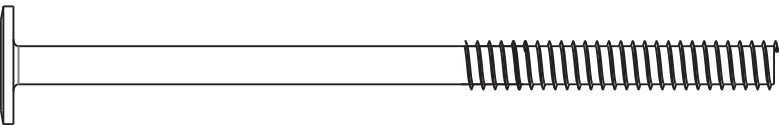
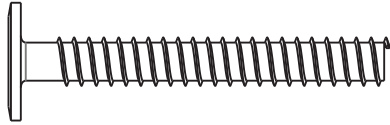
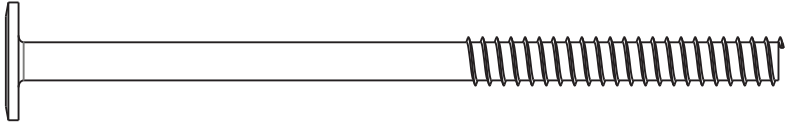
DA8377 / DA8377-E / DA8377-BL / DA8377-BK / DA8377-GR

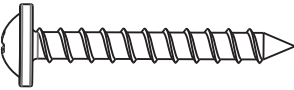
## LISTE DE QUINCAILLERIE

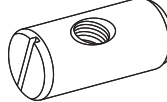
<b>1</b>	 <p style="text-align: center;">1/4" x 100mm RACCORDEMENT (4mm TETE HEX) 8 PCES</p>	<b>2</b>	 <p style="text-align: center;">6.5mm x 48mm RACCORDEMENT (4mm TETE HEX) 6 PCES</p>
<b>3</b>	 <p style="text-align: center;">6.5mm x 100mm RACCORDEMENT (4mm TETE HEX) 16 PCES</p>	<b>4</b>	 <p style="text-align: center;">4mm x 35mm VIS A BOIS 12 PCES</p>
<b>5</b>	 <p style="text-align: center;">4mm x 35mm VIS DE BRIDE 6 PCES</p>	<b>6</b>	 <p style="text-align: center;">10mm x 50mm GOUJON DE BOIS 34 PCES</p>
<b>7</b>	 <p style="text-align: center;">CLÉ ALLEN 1 PCE</p>	<b>8</b>	 <p style="text-align: center;">11.8mm x 15mm ÉCROU TRANSVERSAL 8 PCES</p>

# LIT MEZZANINE JUNIOR SIMPLE

## DA8377 / DA8377-E / DA8377-BL / DA8377-BK / DA8377-GR

### QUINCAILLERIE

DA8377-E (Espresso) DA8377-BL (Bleu) DA8377-BK (Noir) DA8377-GR (Gris)	# de Paquet : <input checked="" type="checkbox"/> TDA8377-BK-00
DA8377 (Blanc)	# de Paquet : <input type="checkbox"/> TDA8377-00



 **Remarque:** Sauf indication contraire dans les instructions, ne pas resserrer complètement les vis et les boulons, jusqu'à ce que l'assemblage soit terminé.

 Les vis et boulons utilisés durant chaque étape sont illustrés en taille réelle au coin inférieur droit de la page.

# LIT MEZZANINE JUNIOR SIMPLE

DA8377 / DA8377-E / DA8377-BL / DA8377-BK / DA8377-GR

## Liste de pièces

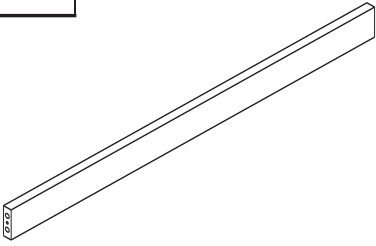
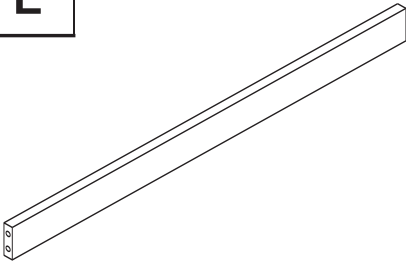
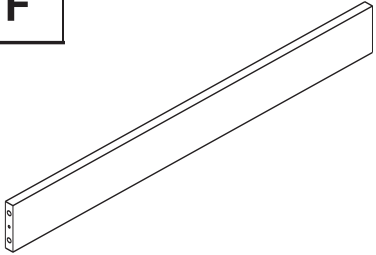

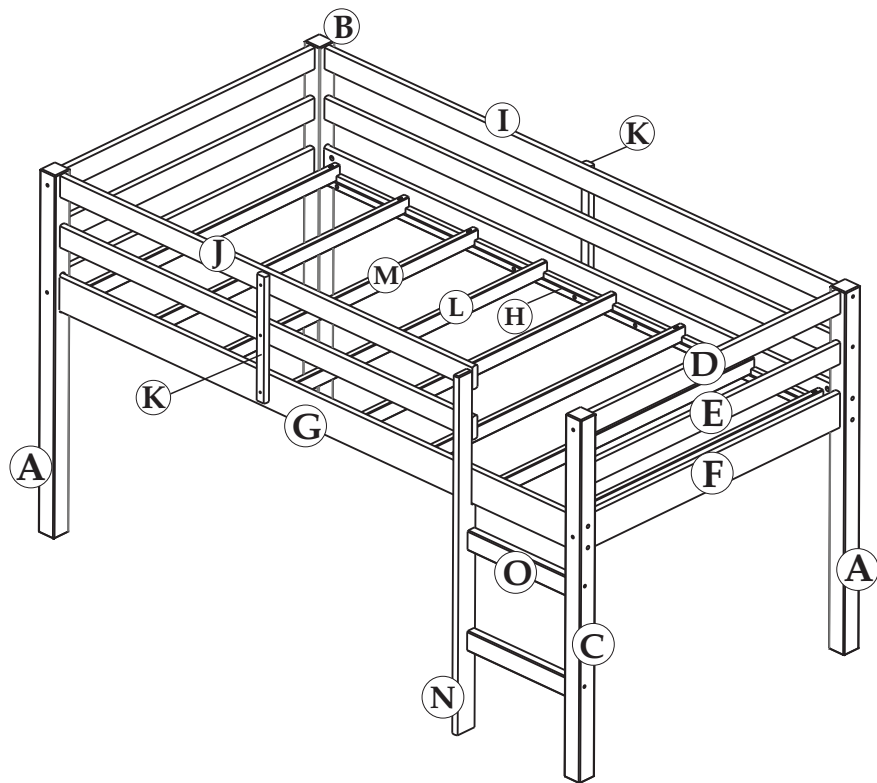

<p><b>A</b></p> 	<p><b>B</b></p> 	<p><b>C</b></p> 
<p>POTEAU 2 PCES</p>	<p>POTEAU 1 PCE</p>	<p>POTEAU 1 PCE</p>
<p><b>D</b></p> 	<p><b>E</b></p> 	<p><b>F</b></p> 
<p>TRAVERSE SUPÉRIEURE TÊTE DE LIT 2 PCES</p>	<p>TRAVERSE CENTRALE TÊTE DE LIT 2 PCES</p>	<p>TRAVERSE INFÉRIEURE TÊTE DE LIT 2 PCES</p>

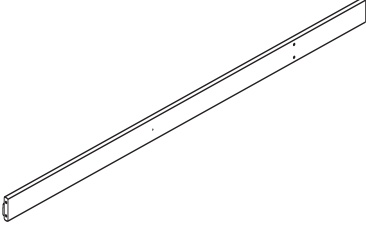
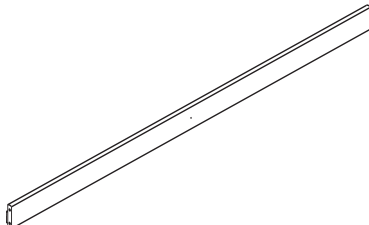
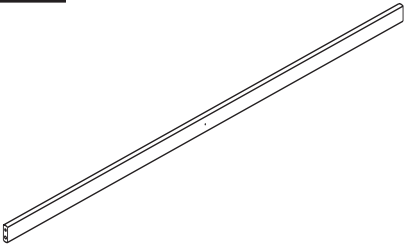
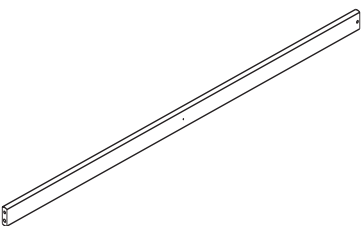

# LIT MEZZANINE JUNIOR SIMPLE

DA8377 / DA8377-E / DA8377-BL / DA8377-BK / DA8377-GR

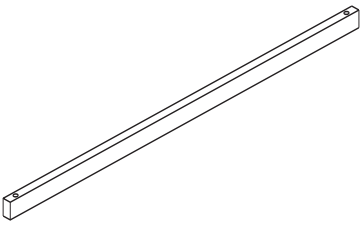
## Liste de pièces

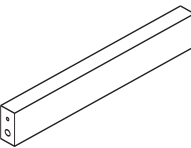
<p><b>G</b></p> 	<p><b>H</b></p> 	<p><b>I</b></p> 
<p>BARRE LATÉRALE (avec 3 trous) 1 PCE</p>	<p>BARRE LATÉRALE (avec 1 trou) 1 PCE</p>	<p>BARRIÈRE LONGUE 2 PCES</p>
<p><b>J</b></p> 	<p><b>K</b></p> 	<p><b>L</b></p> 
<p>BARRIÈRE COURTE 2 PCES</p>	<p>SUPPORT BARRIÈRE 2 PCES</p>	<p>LATTE 2 PCES</p>
<p><b>M</b></p> 	<p><b>N</b></p> 	<p><b>O</b></p> 
<p>LATTE 6 PCES</p>	<p>EXTRÉMITÉ DE L'ÉCHELLE 1 PCE</p>	<p>MARCHE 2 PCES</p>

# LIT MEZZANINE JUNIOR SIMPLE

## DA8377 / DA8377-E / DA8377-BL / DA8377-BK / DA8377-GR

### PIÈCES

Pour des pièces de rechange, visitez [www.dhpfurniture.com/fre/replacement-parts](http://www.dhpfurniture.com/fre/replacement-parts)

**IMPORTANT:** La liste des références ci-dessous est propre à votre produit. Veuillez l'avoir sous la main lorsque vous appelez pour des pièces de rechange.

 Avant de jeter les boîtes en carton, assurez-vous qu'elles soient vides. Vérifiez que vous avez reçu tous les composants nécessaires à l'assemblage en les comparant avec le tableau des pièces (illustrations disponibles dans la section en anglais).

LISTE DES PIÈCES					
ÉTIQUETTE DES PIÈCES	DA8377 (Blanc)	DA8377-E (Espresso)	DA377-BL (Bleu)	DA8377-BK (Noir)	DA8377-GR (Gris)
A	T995720	T995870	T996020	T996170	T996320
B	T995730	T995880	T996030	T996180	T996330
C	T995740	T995890	T996040	T996190	T996340
D	T995750	T995900	T996050	T996200	T996350
E	T995760	T995910	T996060	T996210	T996360
F	T995770	T995920	T996070	T996220	T996370
G	T995780	T995930	T996080	T996230	T996380
H	T995790	T995940	T996090	T996240	T996390
I	T995800	T995950	T996100	T996250	T996400
J	T995810	T995960	T996110	T996260	T996410
K	T995820	T995970	T996120	T996270	T996420
L	T995830	T995980	T996130	T996280	T996430
M	T995840	T995990	T996140	T996290	T996440
N	T995850	T996000	T996150	T996300	T996450
O	T995860	T996010	T996160	T996310	T996460



# LIT MEZZANINE JUNIOR SIMPLE

DA8377 / DA8377-E / DA8377-BL / DA8377-BK / DA8377-GR

## ÉTAPE 1

Une des traverse supérieure de tête de lit (D) porte une étiquette, utilisez-la dans cette étape.

Insérez les goujons en bois (6) aux extrémités de la traverse supérieure de tête de lit (D), des traverses inférieures de tête de lit (F) et de la traverse centrale de tête de lit (E).

Fixez les traverses de tête de lit (D, F, E) aux poteaux (A) et (B) à l'aide des raccordements pour bois (3), comme illustré ci-dessous.

Utilisez la clé Allen (7) pour serrer les raccordements bois.

Répétez l'étape précédente pour assembler l'autre tête de lit à l'aide des montants inférieurs (C) et (A).

**NOTE:** Rapprochez ou écartez les traverses de tête de lit (D, F, E) pour permettre aux chevilles de bois (6) de s'aligner avec les trous des montants (A) et (B).

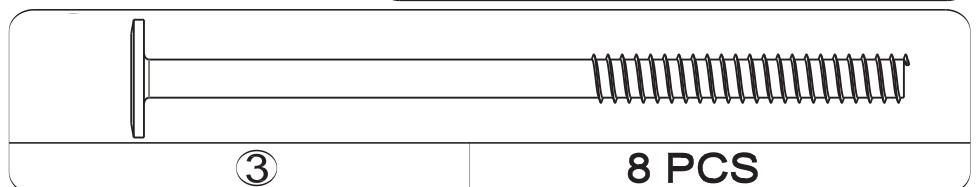
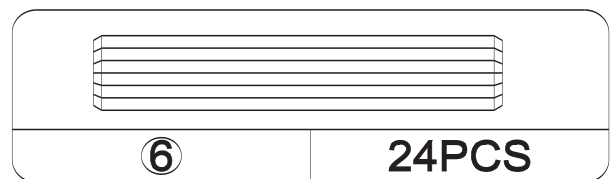
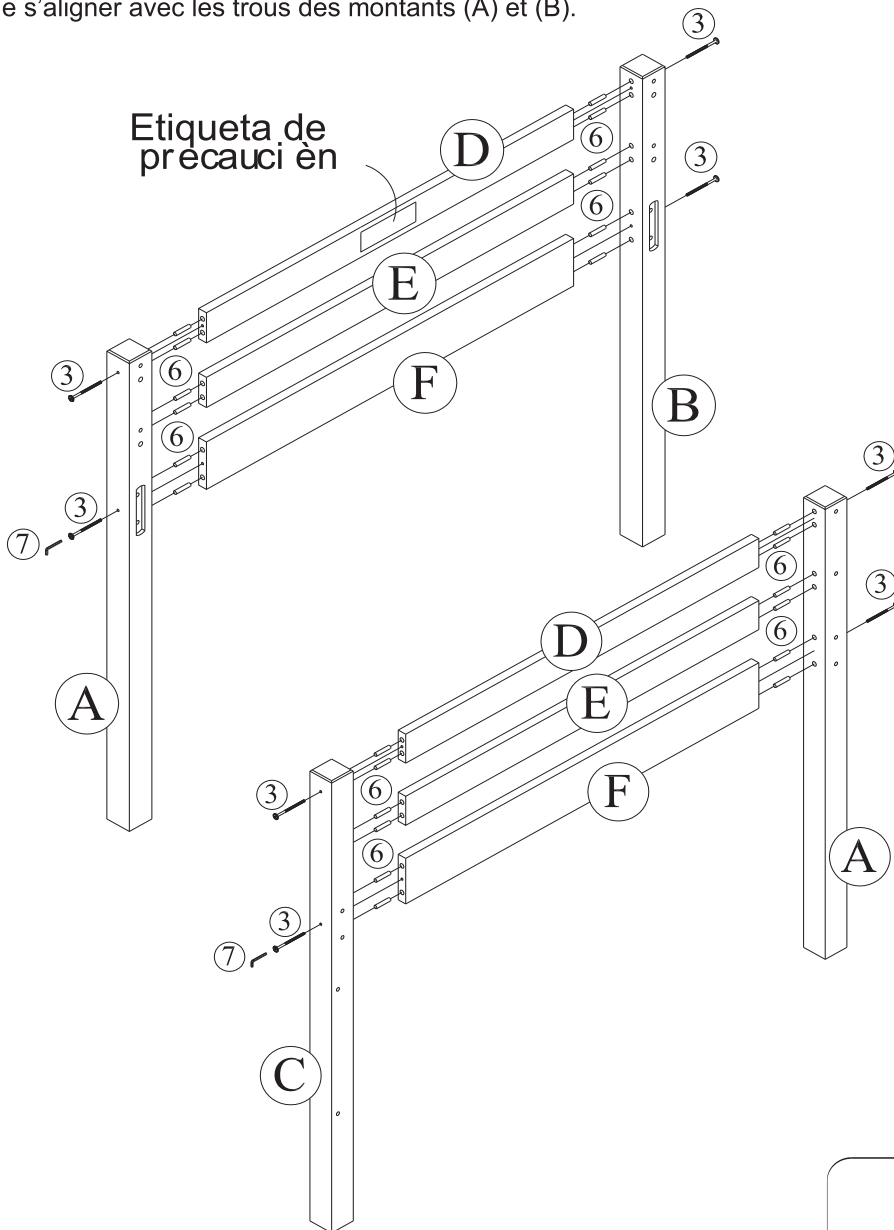

# LIT MEZZANINE JUNIOR SIMPLE

## DA8377 / DA8377-E / DA8377-BL / DA8377-BK / DA8377-GR

### ÉTAPE 2

Insérez des goujons en bois (6) à chaque extrémité des barrières longues (I). Attachez les barrières longues (I) et les rails latéraux (G) et (H) aux poteaux (A et B) et (A & C) comme indiqué ci-dessous. Fixez les barres latérales (G) et (H) avec les raccords (1) et les écrous transversales (8). Fixer les barrières longues (I) avec les raccords pour bois (3). Utilisez la clé Allen (7) pour serrer tous les raccords pour bois.

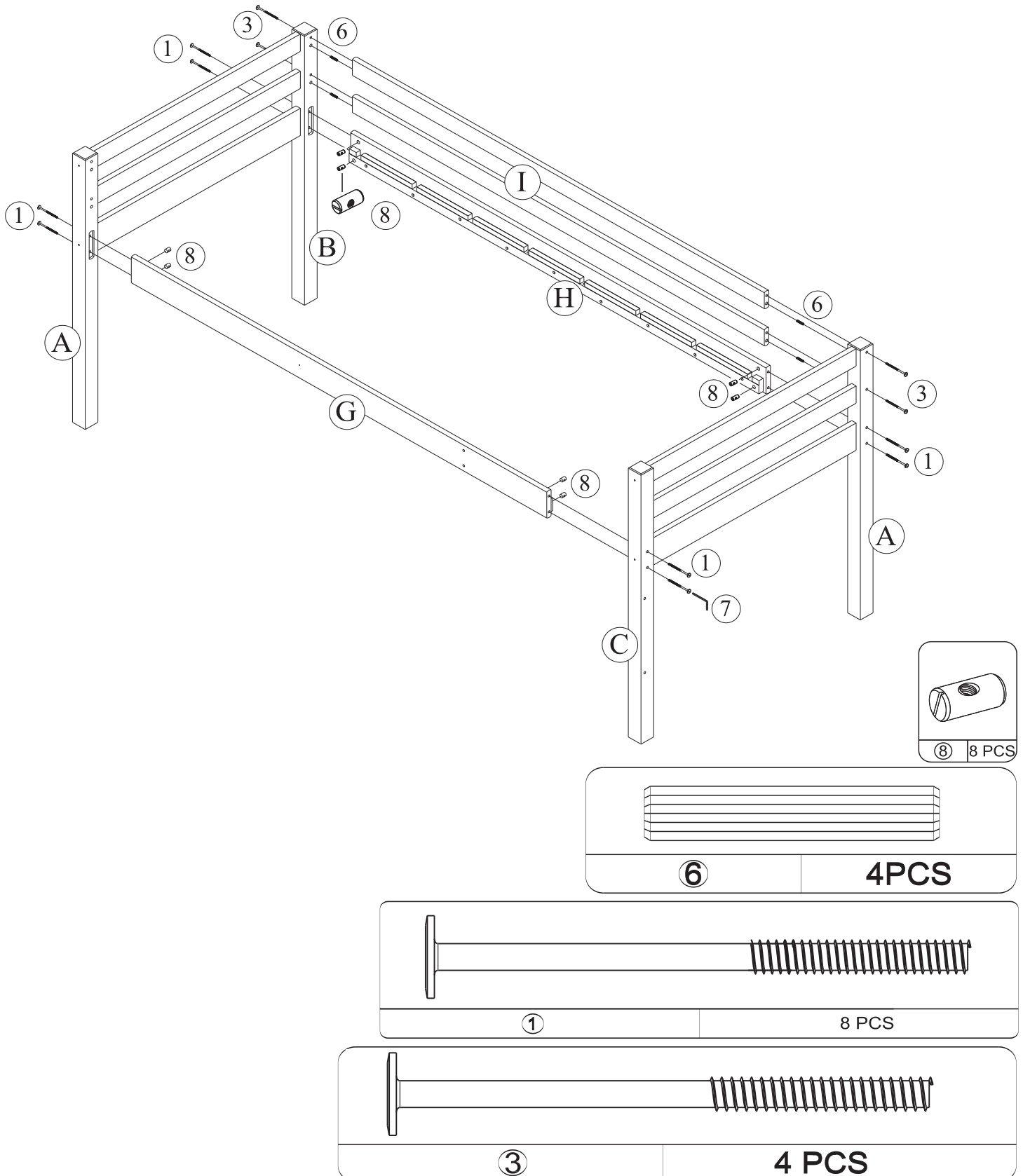

# LIT MEZZANINE JUNIOR SIMPLE

DA8377 / DA8377-E / DA8377-BL / DA8377-BK / DA8377-GR

## ÉTAPE 3

Insérez deux lattes (L) dans les fentes centrales des barres latérales (G) et (H), comme indiqué ci-dessous.

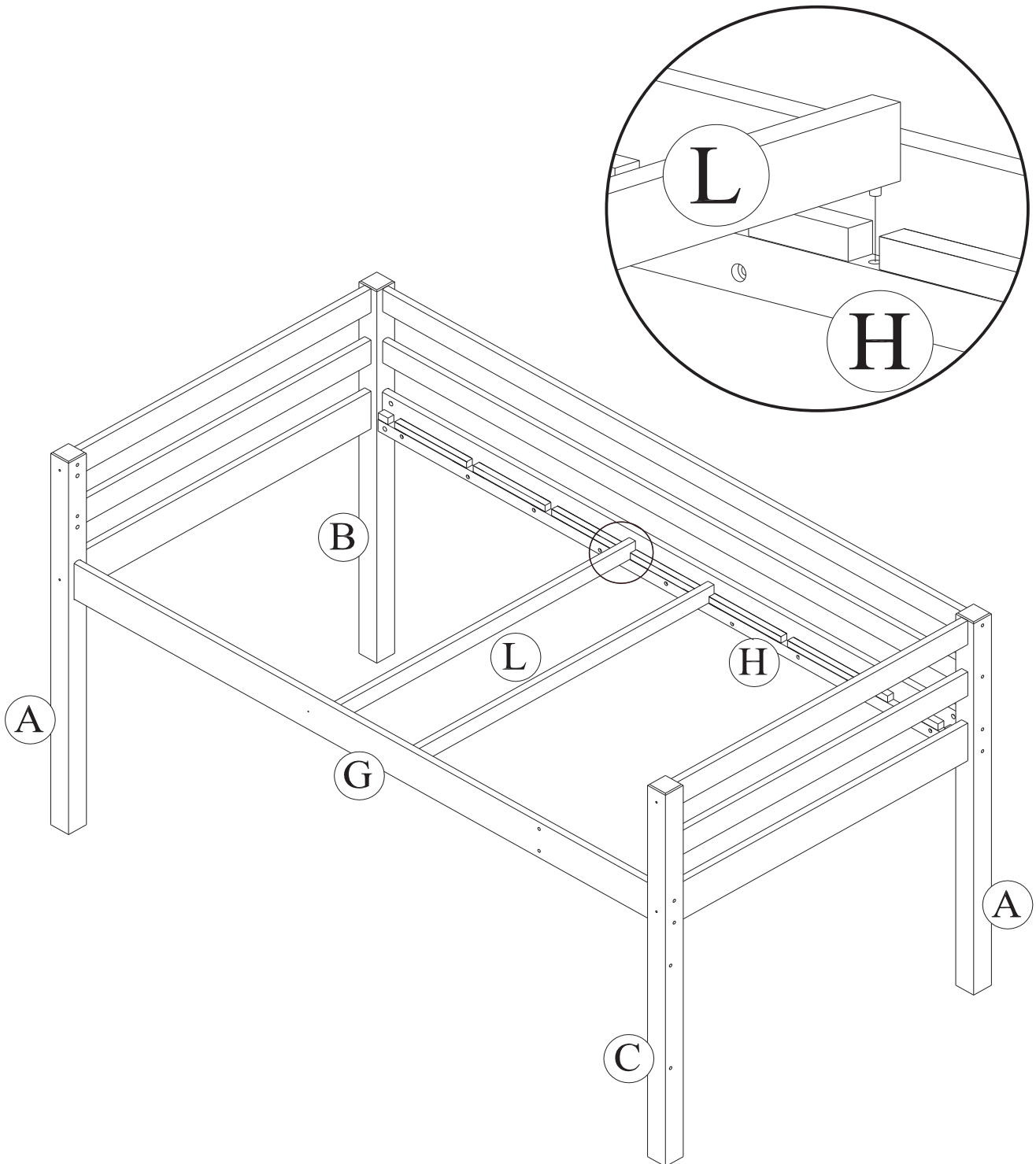

# LIT MEZZANINE JUNIOR SIMPLE

DA8377 / DA8377-E / DA8377-BL / DA8377-BK / DA8377-GR

## ÉTAPE 4

Insérez les lattes (M) dans les trous restants des barres latérales (G) et (H).

Fixez les lattes (M) sur les barres latérales (G) et (H) avec des vis à bois (4) à l'aide d'un tournevis cruciforme (non fourni).

**NOTE:** Les lamelles (M) et (L) seront placées entre deux blocs de bois.

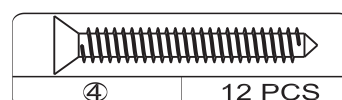
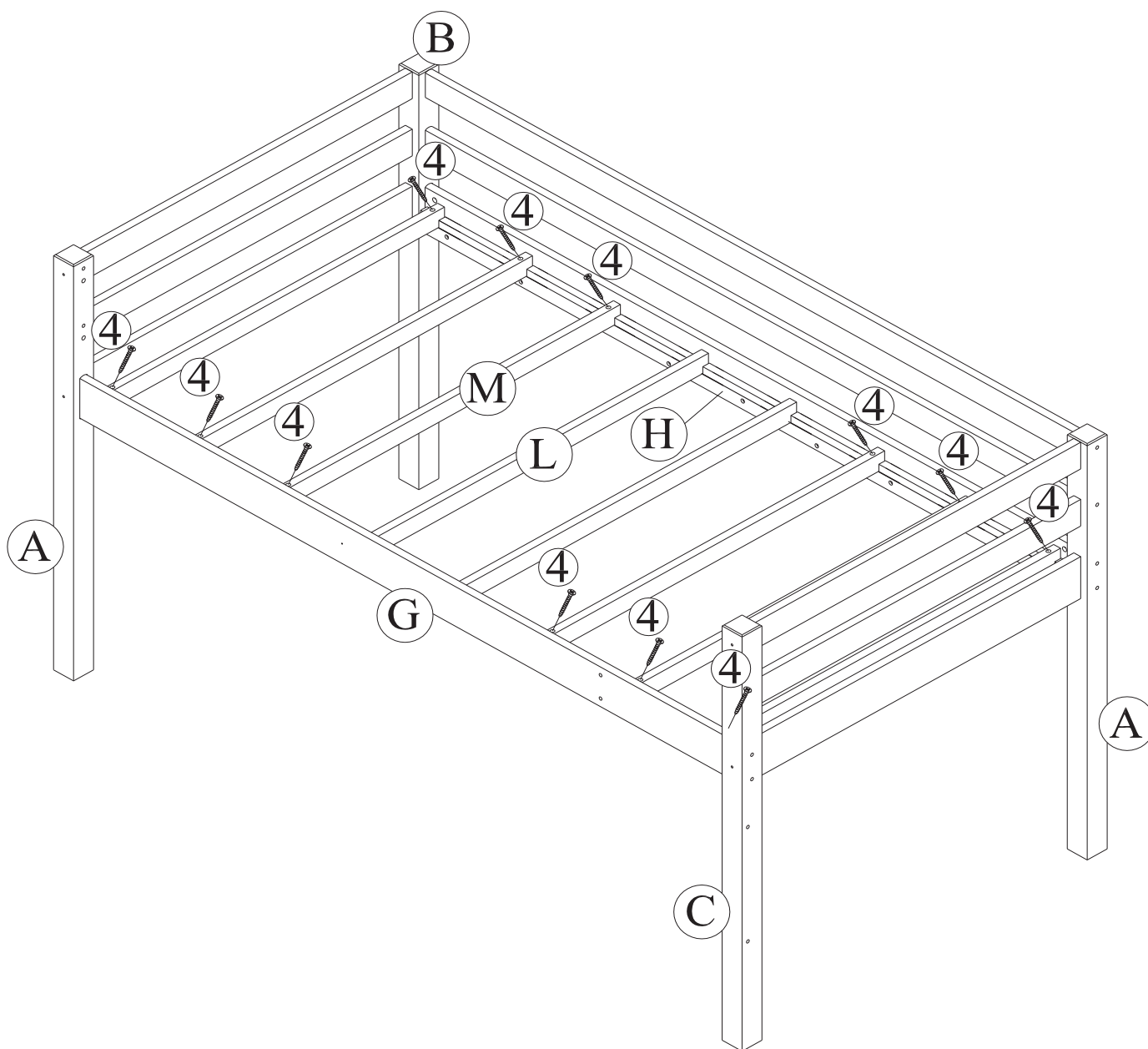

# LIT MEZZANINE JUNIOR SIMPLE

DA8377 / DA8377-E / DA8377-BL / DA8377-BK / DA8377-GR

## ÉTAPE 5

Insérez les goujons en bois (6) aux extrémités des barrières courtes (J). Attachez de barrières courtes (J) au poteau (A) avec les raccords pour bois (3). Fixez le support de barrière (K) aux barrières courtes (J) et aux barres latérales (G) à l'aide de vis à bois (5). Fixez le support de barrière (K) sur les longs garde-corps (I) et les barres latérales (H) à l'aide des vis à bois (5).

Utilisez un tournevis cruciforme (non fourni) pour installer les vis (5).

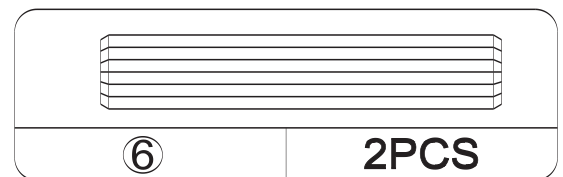
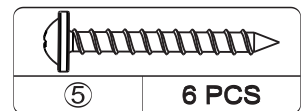
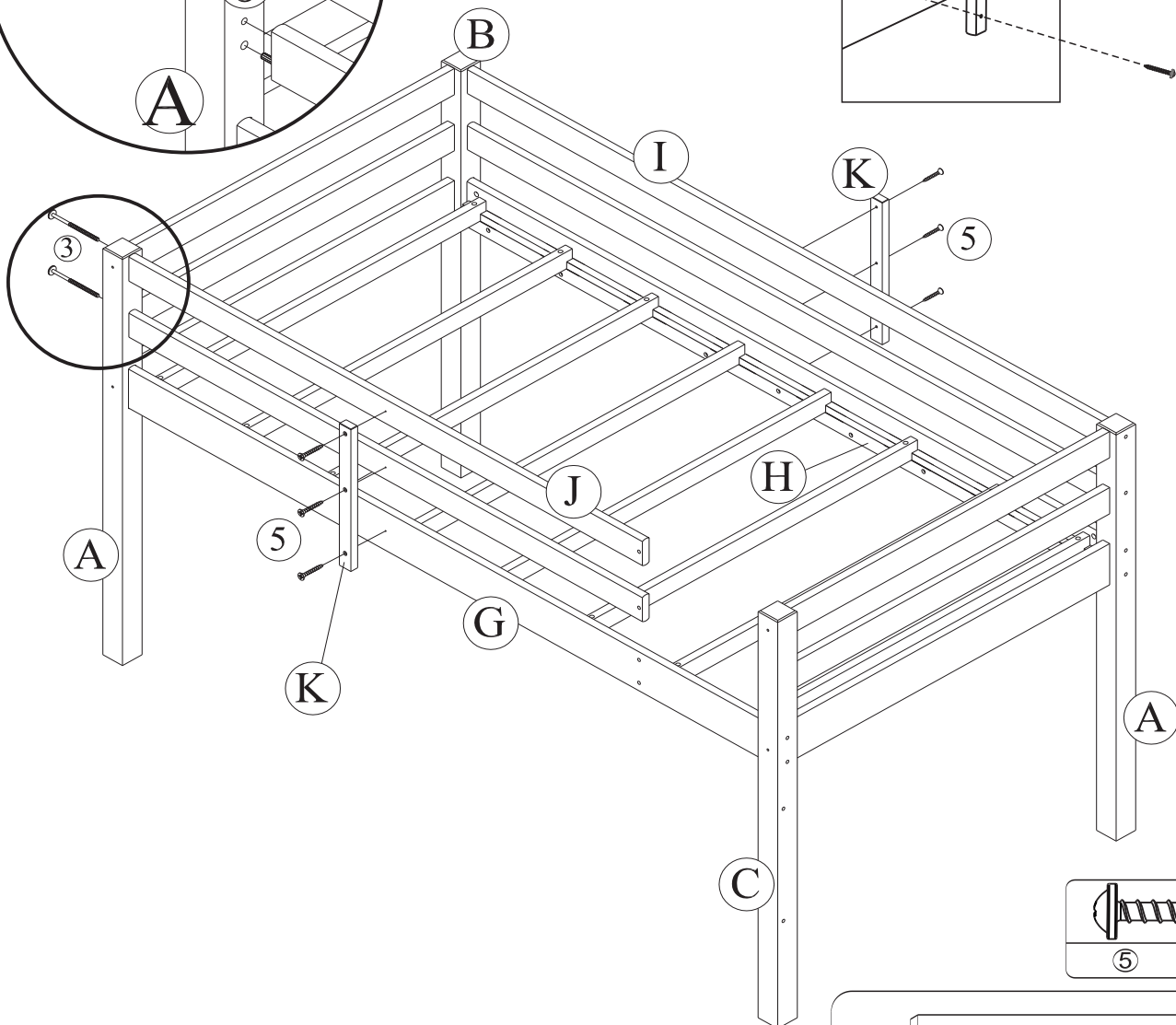
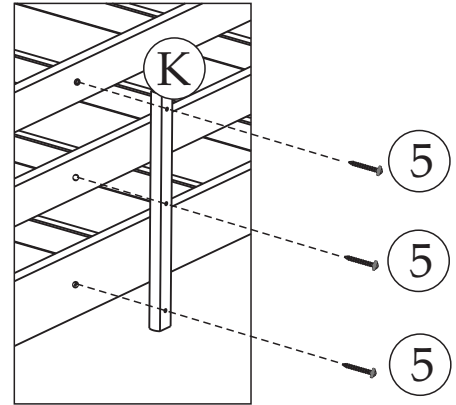
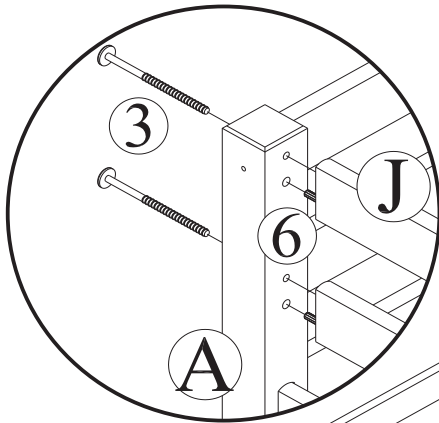

# LIT MEZZANINE JUNIOR SIMPLE

DA8377 / DA8377-E / DA8377-BL / DA8377-BK / DA8377-GR

## ÉTAPE 6

Insérez les goujons en bois (6) aux extrémités des marches d'échelle (O).

Fixez les échelons (O) à l'extrémité de l'échelle (N) à l'aide des raccordements pour bois (2) et au poteau (C) avec les raccordements pour bois (3).

**NOTE:** Ne serrez pas complètement les raccordements. Les raccordements desserrés faciliteront l'assemblage dans les étapes suivantes.

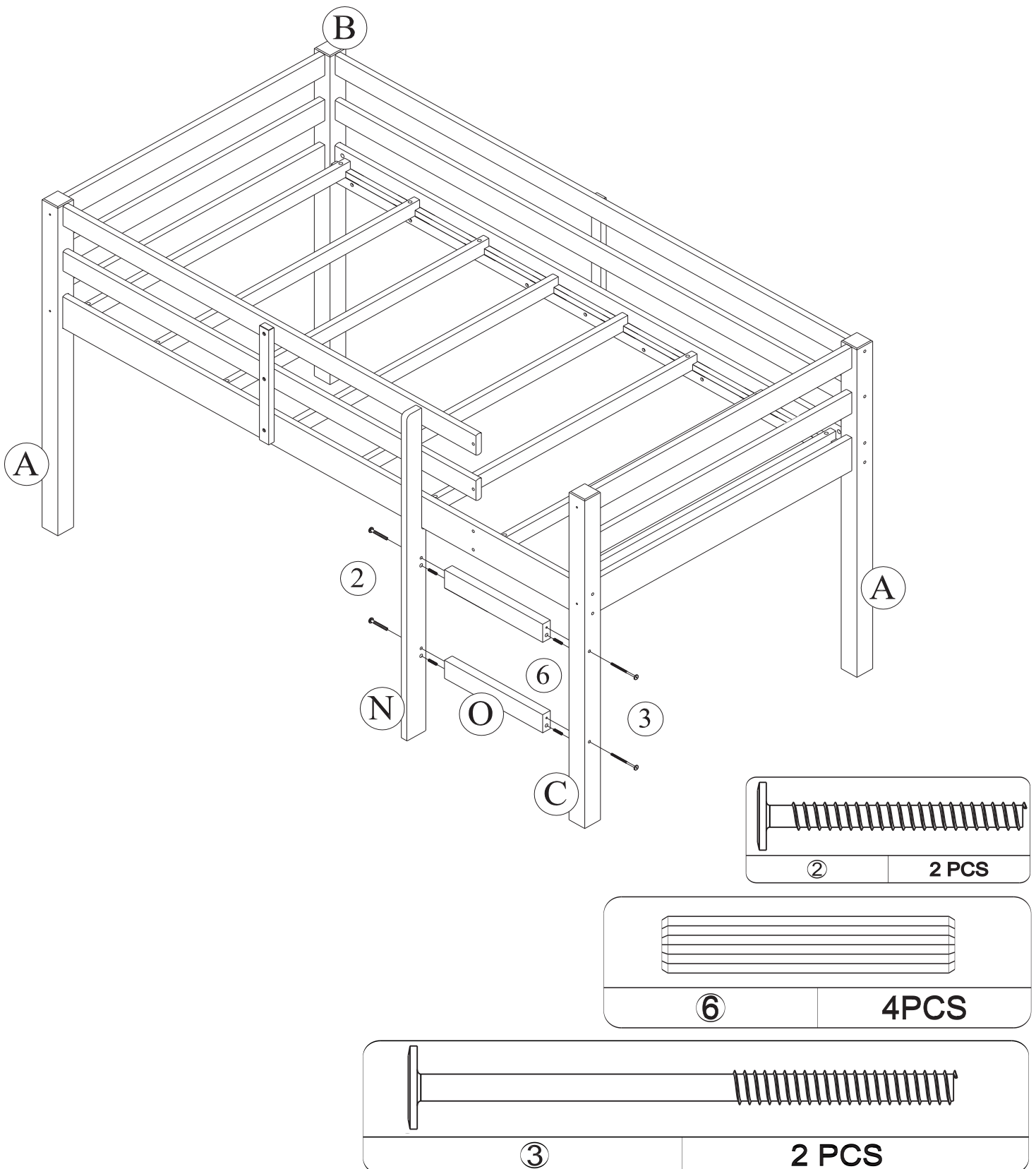

# LIT MEZZANINE JUNIOR SIMPLE

DA8377 / DA8377-E / DA8377-BL / DA8377-BK / DA8377-GR

## ÉTAPE 7

Fixez l'échelle aux extrémités des barrières courtes (J), et à la barre latérale (G) avec les raccords (2) comme indiqué ci-dessous.

Utilisez la clé Allen (7) pour serrer tous les raccords déjà installés.

**NOTE:** Si la latte (M) recouvre les trous de montage de l'échelle, retirez-la temporairement (M) et placez-la après l'échelle est fixée.

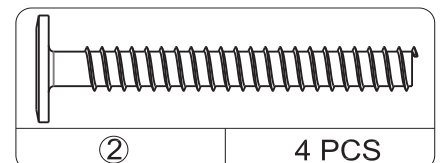
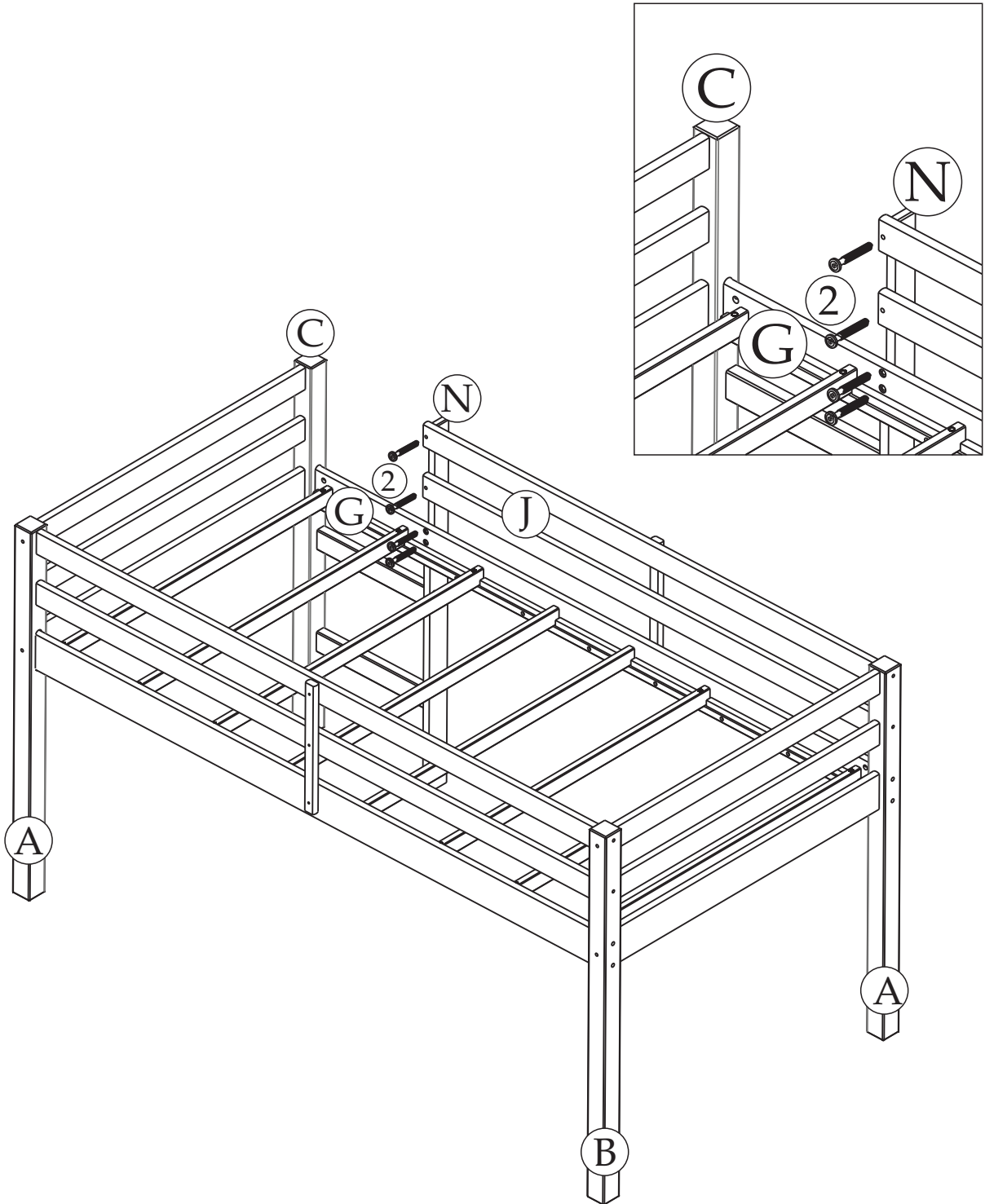

# LIT MEZZANINE JUNIOR SIMPLE

DA8377 / DA8377-E / DA8377-BL / DA8377-BK / DA8377-GR



**ATTENTION:** Cette unité est destinée à être utilisée seulement avec des produits et/ou les poids maximum indiqués. L'utilisation avec d'autres produits et/ou des produits plus lourds que les poids maximum indiqués peut entraîner une instabilité ou causer des blessures.

**NE PAS PERMETTRE DE SE CHAMAILLER SUR OU SOUS LE LIT ET NE PAS SAUTER SUR LE**

**NE PAS PERMETTRE À DES ENFANTS ÂGÉS DE MOINS DE 4 ANS D'UTILISER LE LIT SUPÉRIEUR. LE LIT EST CONÇU POUR DES ENFANTS DONT L'ÂGE SE SITUE À PARTIR DE 4 ANS JUSQU'À JEUNES ADOS.**

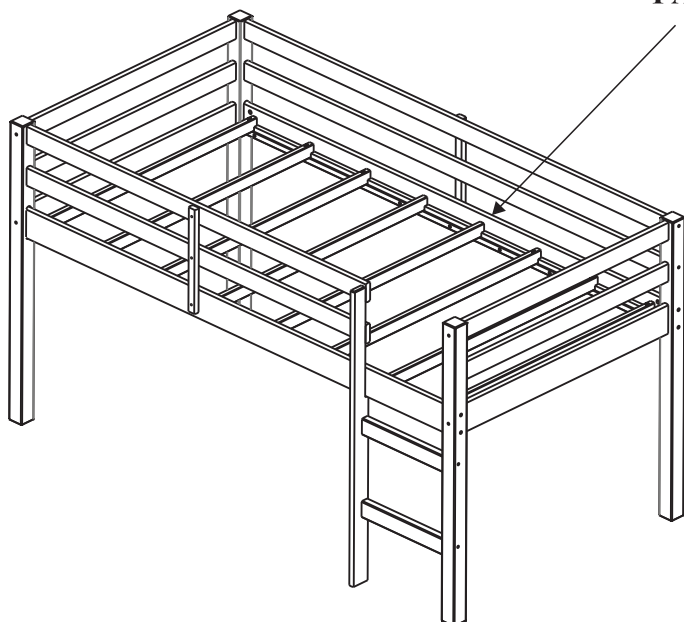

**POIDS MAXIMUM :  
165 LBS / 75 KGS**

**UTILISEZ SEULEMENT DES MATELAS À RESSORTS SUR LES LITS SUPÉRIEUR. À DÉFAUT DE QUOI, DES BLESSURES PEUVENT SE PRODUIRE.**

**UTILISEZ SEULEMENT DES MATELAS DE 188-191 CM (74"-75") DE LONG ET 95-98 CM (37 1/2" - 38 1/2") DE LARGE SUR LE LIT SUPÉRIEUR. ASSUREZ-VOUS QUE L'ÉPAISSEUR DU MATELAS N'EXCÈDE PAS 15 CM (6").**

C'est tout! Vous avez terminé le montage de votre lit

**NE PAS RETOURNER CE PRODUIT AU DÉTAILLANT.**

Si une pièce est manquante ou endommagée, contactez notre Service clientèle. Nous remplacerons la pièce **GRATUITEMENT**.

**TÉL. # : 1-800-267-1739**

**Courriel : [cs@dhpfniture.com](mailto:cs@dhpfniture.com)**